



## DCR 50 Scan Engine



<b>1</b>	<b>About this document .....</b>	<b>5</b>
1.1	Used symbols and signal words .....	5
<b>2</b>	<b>Safety .....</b>	<b>6</b>
2.1	Intended use .....	6
2.2	Foreseeable misuse .....	6
2.3	Competent persons .....	7
2.4	Disclaimer .....	7
<b>3</b>	<b>Device description .....</b>	<b>8</b>
3.1	Device overview .....	8
3.1.1	About the DCR 50 scan engine .....	8
3.1.2	Stand-alone operation .....	8
3.2	Performance characteristics .....	8
3.3	Device construction .....	9
3.4	Connection technology .....	9
<b>4</b>	<b>Mounting .....</b>	<b>10</b>
4.1	Selecting a mounting location .....	10
<b>5</b>	<b>Electrical connection .....</b>	<b>11</b>
5.1	Voltage supply .....	11
5.2	Pin assignment .....	11
5.3	Switching input / switching output .....	11
5.3.1	Switching input .....	11
5.3.2	Switching output .....	12
5.4	PC or terminal connection .....	13
5.5	Cable lengths and shielding .....	13
<b>6</b>	<b>Configuration and diagnostics software - Sensor Studio .....</b>	<b>14</b>
6.1	System requirements .....	14
6.2	Installing Sensor Studio configuration software .....	15
6.2.1	Downloading configuration software .....	15
6.2.2	Installing the Sensor Studio FDT frame .....	15
6.2.3	Installing the communication DTM and the device DTM .....	15
6.2.4	Connecting device to PC .....	15
6.3	Starting the Sensor Studio configuration software .....	16
6.4	Exiting Sensor Studio .....	17
6.5	Configuration parameters .....	18
6.5.1	Control tab .....	18
6.5.2	Decode tab .....	19
6.5.3	Communications tab .....	21
6.5.4	Diagnosis / Terminal .....	22
<b>7</b>	<b>Starting up the device - Configuration .....</b>	<b>23</b>
7.1	Measures to be performed prior to the initial commissioning .....	23
7.2	Starting the device .....	23
7.2.1	Interface .....	23
7.2.2	Online commands .....	23
7.2.3	Problems .....	23
7.3	Setting the communication parameters .....	23

<b>8</b>	<b>Configuration control .....</b>	<b>24</b>
8.1	Configuration command architecture .....	24
8.2	Supported commands .....	25
8.2.1	Symbology .....	25
8.2.2	Communications .....	40
8.2.3	USB and HID .....	41
8.2.4	Packet and protocol parameters .....	44
8.2.5	Decoder and general decoding parameters .....	45
8.2.6	Power mode parameters .....	49
8.2.7	General reader information .....	50
8.2.8	Reader configuration .....	52
8.2.9	General firmware operation .....	52
8.2.10	General reader feedback parameters .....	53
8.2.11	Setup default AGC mode .....	53
8.2.12	Setup AGC parameters .....	54
8.2.13	Setup motion detection parameters .....	55
8.2.14	Setup camera parameters .....	57
8.2.15	Command barcode format .....	57
8.3	Motion detection .....	58
8.4	Data formatting .....	59
<b>9</b>	<b>Command protocol .....</b>	<b>61</b>
9.1	General commands .....	61
9.1.1	Command packet .....	61
9.1.2	Device acknowledgement .....	63
9.1.3	Response packet .....	64
9.1.4	Host acknowledgement .....	64
9.1.5	Example 1: Enabling Code 93 upon startup .....	64
9.1.6	Example 2: Getting information about a device after startup .....	66
9.2	Barcode decoding .....	69
<b>10</b>	<b>Care, maintenance and disposal .....</b>	<b>70</b>
10.1	Cleaning .....	70
10.2	Servicing .....	70
10.3	Disposing .....	70
<b>11</b>	<b>Service and support .....</b>	<b>71</b>
11.1	What to do should servicing be required? .....	71
<b>12</b>	<b>Technical data .....</b>	<b>72</b>
12.1	General specifications .....	72
12.2	Reading fields .....	73
12.3	Dimensioned drawings .....	75
<b>13</b>	<b>Order guide and accessories .....</b>	<b>76</b>
13.1	Type overview .....	76
13.2	Accessories .....	76
<b>14</b>	<b>EC Declaration of Conformity .....</b>	<b>77</b>
<b>15</b>	<b>Appendix .....</b>	<b>78</b>
15.1	Bar code samples .....	78
15.2	Configuration via configuration codes .....	79



# 1 About this document

## 1.1 Used symbols and signal words

Tab. 1.1: Warning symbols and signal words

	Symbol indicating dangers to persons
NOTE	Signal word for property damage Indicates dangers that may result in property damage if the measures for danger avoidance are not followed.

Tab. 1.2: Other symbols

	Symbol for tips Text passages with this symbol provide you with further information.
	Symbols for action steps Text passages with this symbol instruct you to perform actions.
	Symbol for action results Text passages with this symbol describe the result of the preceding action.

Tab. 1.3: Terms and abbreviations

BCL	Bar code reader
CMOS	Semiconductor process for implementing integrated circuits (Complementary Metal-Oxide-Semiconductor)
DCR	Image-based code reader (Dual Code Reader)
DTM	Software device manager (Device Type Manager)
EMC	Electromagnetic compatibility
EN	European standard
FDT	Software frame for management of device managers (DTM) (Field Device Tool)
FE	Functional earth
GUI	Graphical user interface
HID	Device class for input devices with which users directly interact (Human Interface Device)
IO or I/O	Input/Output
LED	LED (Light Emitting Diode)
PLC	Programmable Logic Control (corresponds to Programmable Logic Controller (PLC))

**2 Safety**

This scan engine was developed, manufactured and tested in accordance with the applicable safety standards. It corresponds to the state of the art.



**2.1 Intended use**

The DCR 50 scan engine is designed as an installation scanner with integrated decoder for all of the most popular 1D and 2D codes for automatic object recognition.

**Areas of application**

The DCR 50 scan engine is intended especially for the following areas of application:

- In automatic analyzers
- For space-critical code reading tasks
- For installation in a housing or beneath covers

 <b>CAUTION</b>	
	<p><b>Observe intended use!</b></p> <p>The protection of personnel and the device cannot be guaranteed if the device is operated in a manner not complying with its intended use.</p> <ul style="list-style-type: none"> <li>↳ Only operate the device in accordance with its intended use.</li> <li>↳ Leuze electronic GmbH + Co. KG is not liable for damages caused by improper use.</li> <li>↳ Read these operating instructions before commissioning the device. Knowledge of the operating instructions is an element of proper use.</li> </ul>

<b>NOTICE</b>	
	<p><b>Comply with conditions and regulations!</b></p> <ul style="list-style-type: none"> <li>↳ Observe the locally applicable legal regulations and the rules of the employer's liability insurance association.</li> </ul>

**2.2 Foreseeable misuse**

Any use other than that defined under "Intended use" or which goes beyond that use is considered improper use.

In particular, use of the device is not permitted in the following cases:

- in rooms with explosive atmospheres
- in circuits which are relevant to safety
- for medical purposes

<b>NOTICE</b>	
	<p><b>Do not modify or otherwise interfere with the device!</b></p> <ul style="list-style-type: none"> <li>↳ Do not carry out modifications or otherwise interfere with the device. The device must not be tampered with and must not be changed in any way.</li> <li>↳ The device must not be opened. There are no user-serviceable parts inside.</li> <li>↳ Repairs must only be performed by Leuze electronic GmbH + Co. KG.</li> </ul>

## 2.3 Competent persons

Connection, mounting, commissioning and adjustment of the device must only be carried out by competent persons.

Prerequisites for competent persons:

- They have a suitable technical education.
- They are familiar with the rules and regulations for occupational safety and safety at work.
- They are familiar with the operating instructions for the device.
- They have been instructed by the responsible person on the mounting and operation of the device.

### **Certified electricians**

Electrical work must be carried out by a certified electrician.

Due to their technical training, knowledge and experience as well as their familiarity with relevant standards and regulations, certified electricians are able to perform work on electrical systems and independently detect possible dangers.

In Germany, certified electricians must fulfill the requirements of accident-prevention regulations BGV A3 (e.g. electrician foreman). In other countries, there are respective regulations that must be observed.

## 2.4 Disclaimer

Leuze electronic GmbH + Co. KG is not liable in the following cases:

- The device is not being used properly.
- Reasonably foreseeable misuse is not taken into account.
- Mounting and electrical connection are not properly performed.
- Changes (e.g., constructional) are made to the device.

## 3 Device description

### 3.1 Device overview

#### 3.1.1 About the DCR 50 scan engine

The code reader is based on a scan engine with CMOS imager with integrated decoder for all of the most popular 1D and 2D codes such as DataMatrix, Aztec, QR Code, 2/5 Interleaved, Code 39, Code 128, UPC/EAN etc.

The many possible configurations of the device allow it to be adapted to a multitude of reading tasks. Due to the small dimensions of the unit and the large reading field, the device can also be used in highly constrained spaces.

Information on technical data and characteristics: see chapter 12 "Technical data".

#### 3.1.2 Stand-alone operation

The scan engine is operated as a single "stand-alone" device. It is equipped with a 6-pin Molex connector for the power supply electrical connection, the interface, the trigger input, and the switching output.

### 3.2 Performance characteristics

- High-performance miniature CMOS imager scan engine
- Compact design for simple integration, even in constrained spaces
- Reading of extremely small high-density codes and recording of standard codes in a large reading area using a special optical system
- Reading of shiny surfaces using a gloss reduction process
- Excellent decoding characteristics
- Clearly visible alignment LED
- RS 232 interface, triggering input, switching output

### 3.3 Device construction

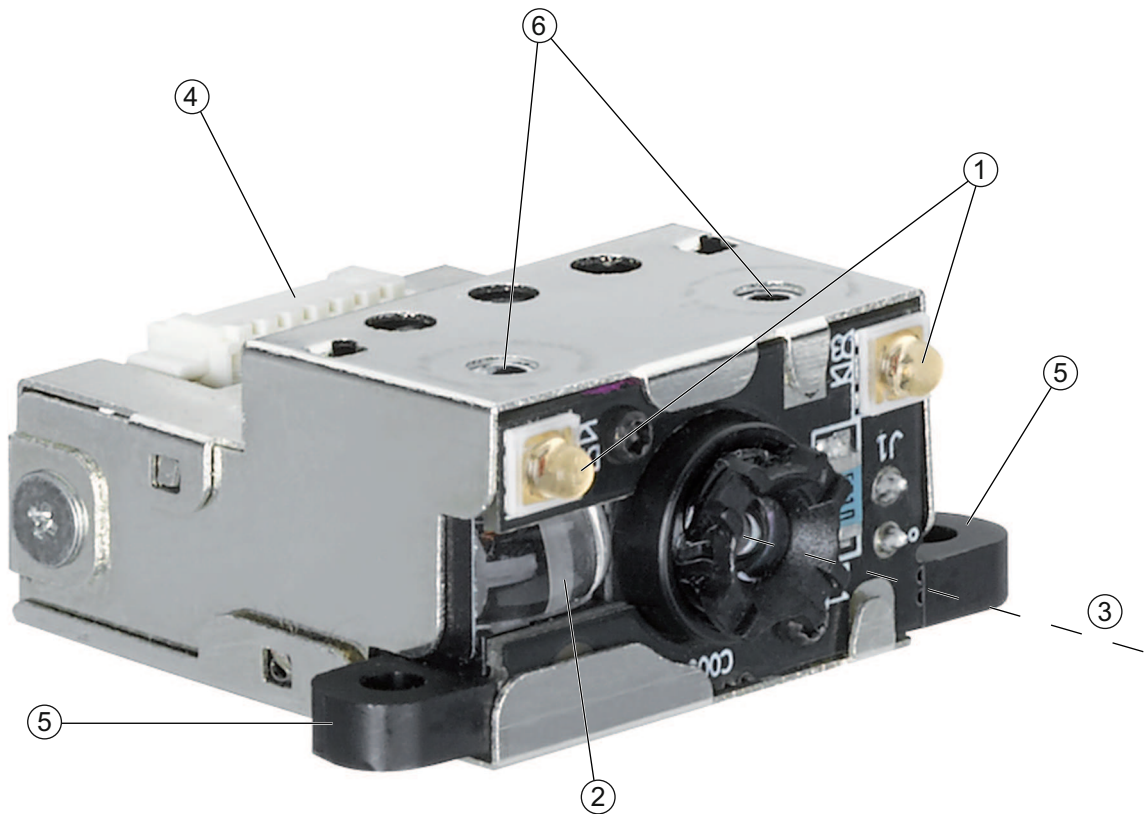

- 1 Two integrated LEDs for illumination (red light)
- 2 One integrated target LED (blue light)
- 3 Center of optical axis
- 4 Connector Molex (53261-0671), 6-pin
- 5 Mounting tabs, M2.5 through-hole
- 6 Inserts for M1.8 self-tapping screws, 2 mm deep

Fig. 3.1: DCR 50 device construction

### 3.4 Connection technology

6-pin Molex connector (53261-0671)

## 4 Mounting

The scan engine can be attached at two M2.5 through-hole mounting tabs.

In addition, two 2 mm deep inserts for M1.8 self-tapping screws are provided on top of the scan engine.

### 4.1 Selecting a mounting location

<b>NOTICE</b>	
	The size of the code module influences the maximum reading distance and the width of the reading field. Therefore, when selecting a mounting location and/or the code label, take into account the different reading characteristics of the scanner with various code modules.

<b>NOTICE</b>	
	<p><b>Observe when choosing the mounting location!</b></p> <ul style="list-style-type: none"> <li>↳ Maintaining the required environmental conditions (temperature, humidity).</li> <li>↳ Possible soiling of the reading window due to liquids, abrasion by boxes, or packaging material residues.</li> <li>↳ Lowest possible chance of damage to the scanner by mechanical collision or jammed parts.</li> <li>↳ Possible extraneous light influence (no direct sunlight).</li> </ul>

The best read results are obtained when

- the reading distance lies in the middle area of the reading field.
- there is no direct sunlight and extraneous light is avoided.
- the bar code labels are of good print quality and have good contrast ratios.
- you do not use high-gloss labels.
- the bar code or the Data Matrix code is moved past the reading window with an angle of rotation of 10° to 15°.
- the red light beam is narrowed down for its respective reading task in order to avoid reflections on shiny components.

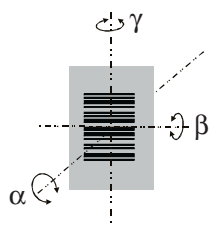

<b>NOTICE</b>	
	The front beam exit of the scan engine is almost vertical to the optics. The code label must be rotated by > 10° to avoid a total reflection of the red light beam in the case of glossy labels.



- $\alpha$  Azimuth angle
  - $\beta$  Angle of inclination
  - $\gamma$  Angle of rotation
- Recommended angle of rotation:  $\gamma > 10^\circ$

Fig. 4.1: Definition of the reading angles

## 5 Electrical connection

 <b>CAUTION</b>	
	<p><b>Safety notices</b></p> <ul style="list-style-type: none"> <li>↪ Before connecting the device, be sure that the supply voltage agrees with the value printed on the name plate.</li> <li>↪ Connection of the device and maintenance work while under voltage must only be carried out by a qualified electrician.</li> <li>↪ The power supply unit for the generation of the supply voltage for the scan engine and the corresponding connection units must have a secure electrical insulation according to IEC 60742 (PELV). For UL applications: only for use in class 2 circuits according to NEC.</li> <li>↪ If faults cannot be cleared, the device should be switched off and protected against accidental use.</li> </ul>

### 5.1 Voltage supply

The scan engine is designed for connection to a 5 V supply voltage.

- +5 V DC (pin 1)
- GND (pin 2)

A MA-CR Modular adapter unit (interface device-to-host to connect to a PC for evaluation, 50128204) with spring terminals, Molex connector, and D-SUB 9-pin socket is available as an accessory (see chapter 13.2 "Accessories").

- With the MA-CR Modular adapter unit, the 6-pin connector of the scan engine can be contacted via a 150 mm long interconnection cable with a 12-pin Molex terminal strip and connected to the PC via the D-SUB 9-pin socket using an RS 232 interconnection cable.
- With the MA-CR Modular adapter unit, the voltage supply of 10 ... 30 V DC can be fed in via spring terminals or, alternatively, 5 V DC can be fed in via a micro USB connector.

### 5.2 Pin assignment

Pin	Signal	IN / OUT
1	VCC / +5 V DC	IN
2	GROUND	IN
3	TRIGGER	IN
4	GOOD READ	OUT
5	RS 232 TX	OUT
6	RS 232 RX	IN

### 5.3 Switching input / switching output

The scan engine has a switching input and a switching output.

- The switching input is used to trigger code reading.
- The switching output signals successful code reading.

#### 5.3.1 Switching input

A read process can be triggered using the trigger input (pin 5) in the **standard setting** (low = active) via the connection to GND (pin 2). We recommend wiring a 2.2 kΩ pull-up resistor as defined cable termination.

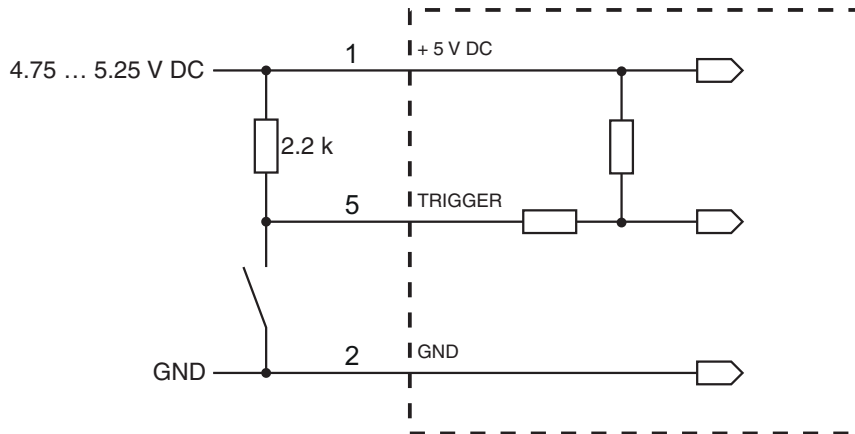

Connection version **NPN**: standard setting (low = active)

Fig. 5.1: Wiring example of the trigger input

### 5.3.2 Switching output

The NPN switching output connection between switching output (pin 4) and GND (pin 2) switches if a code is detected against GND.

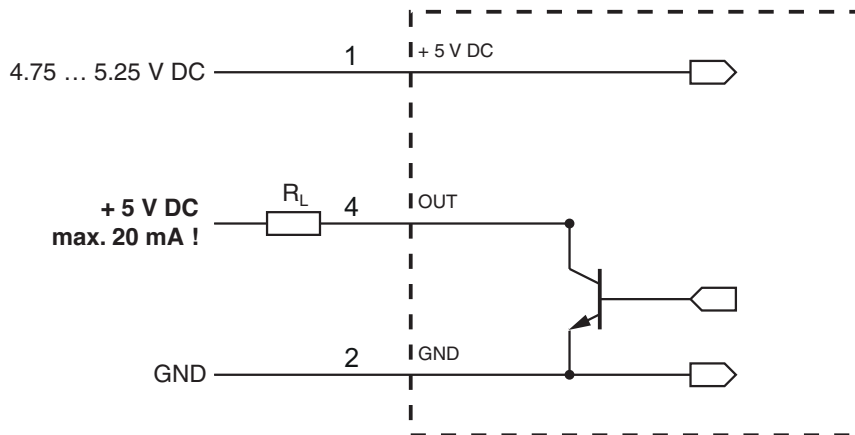

Fig. 5.2: Switching output

**NOTICE**



**Maximum loading of the switching output**

Do not load the switching output of the scan engine with more than 20 mA at +5 ... V DC!

### 5.4 PC or terminal connection

Via the serial interface, you can configure the scan engine by means of a PC or terminal. For this, you need a RS 232 connection that establishes the Rx/D, Tx/D and GND connections between PC and scan engine.

The RS 232 connection can be established in the following ways:

- Direct connection of the plug connector of the scan engine to the PC or terminal via its own connector.
- Connection via a MA-CR modular adapter unit

To simplify the connection of the connection wires to the PC interface, a modular adapter unit (MA-CR) is available for implementing the 6-pin plug connector to D-SUB, 9-pin (see chapter 13.2 "Accessories").

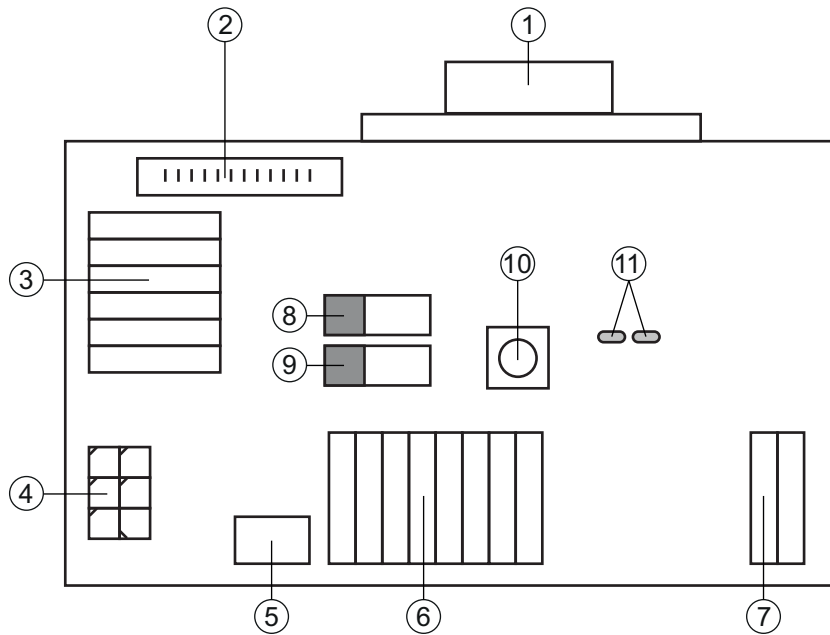

- 1 RS 232 connection
- 2 CR 50 or DCR 80 connection
- 3 DCR 50, DCR 85, CR 100, CR 55 connection
- 4 Molex Micro-Fit, 6-pin
- 5 USB connection
- 6 Connection to machine control, PLC, external voltage supply 5 VDC
- 7 External voltage supply 10 ... 30 VDC
- 8 SWIN DIP switch (level for trigger button; 5 V if the scanner high switching input is active, GND if the low input is active)
- 9 USB/PWR DIP switch (USB position if voltage is supplied via USB; PWR position if voltage is supplied via (7))
- 10 Trigger button
- 11 Status LEDs

Fig. 5.3: Connection options for MA-CR modular adapter unit

### 5.5 Cable lengths and shielding

The maximum cable length is 3 m.

Should a cable extension be necessary, make certain that the cables of the RS 232 interface are shielded.

## 6 Configuration and diagnostics software - Sensor Studio

The *Sensor Studio* configuration software provides a graphical user interface for the operation, configuration and diagnosis of the device via the RS 232 interface.

A device that is not connected to the PC can be configured offline.

Configurations can be saved and reopened as projects for transferring back to the device at a later time.

<b>NOTICE</b>	
	<p>Only use the <i>Sensor Studio</i> configuration software for products manufactured by Leuze electronic.</p> <p>The <i>Sensor Studio</i> configuration software is offered in the following languages: German, English, French, Italian and Spanish.</p> <p>The FDT frame application of the <i>Sensor Studio</i> supports all languages; all languages may not be supported in the device DTM (Device Type Manager).</p>

The *Sensor Studio* configuration software is designed according to the FDT/DTM concept:

- You make the individual configuration settings for the scan engine in the Device Type Manager (DTM).
- The individual DTM configurations of a project can be called up via the frame application of the Field Device Tool (FDT).
- Communication DTM for scan engines: *LeCommInterface*
- Device DTM for scan engine DCR 50

Procedure for the installation of the software and hardware:

- ↪ Install the *Sensor Studio* configuration software on the PC.
- ↪ Install the communication and device DTMs.  
Communication and device DTM are included in the *LeAnalysisCollectionSetup* installation package.
- ↪ Create DCR 50-DTM in the project tree of the *Sensor Studio* FDT frame.
- ↪ Connect scan engine to PC (see chapter 5.4 "PC or terminal connection").

### 6.1 System requirements

To use the *Sensor Studio* configuration software, you need a PC or laptop with the following specifications:

Tab. 6.1: System requirements for *Sensor Studio* installation

Operating system	Windows XP or higher (32 bit, 64 bit) Windows Vista Windows 7 Windows 8
Computer	Processor type: 1 GHz or higher Serial COM interface CD-ROM drive Main memory (RAM): at least 64 MB Keyboard and mouse or touchpad
Graphics card	At least 1024 x 768 pixels
Required hard disk capacity for <i>Sensor Studio</i> and communication DTM	35 MB

<b>NOTICE</b>	
	<p>Administrator privileges on the PC are necessary for installing <i>Sensor Studio</i>.</p>

## 6.2 Installing Sensor Studio configuration software

### NOTICE



The installation files of the *Sensor Studio* configuration software must be downloaded from the Internet at **www.leuze.com**.

For subsequent updates, you can find the most recent version of the *Sensor Studio* installation software on the Internet at **www.leuze.com**.

### 6.2.1 Downloading configuration software

- ↪ Call up the Leuze home page: **www.leuze.com**
- ↪ Enter the type designation or part number of the device as the search term.
- ↪ The configuration software can be found on the product page for the device under the *Downloads* tab.

### 6.2.2 Installing the Sensor Studio FDT frame

### NOTICE



#### First install the software!

- ↪ Do not yet connect the device to the PC. First install the software.

### NOTICE



If FDT frame software is already installed on your PC, you do not need the *Sensor Studio* installation.

You can install the communication DTM and the device DTM in the existing FDT frame. Communication DTM and device DTM are included in the *LeAnalysisCollectionSetup* installation package.

- ↪ Start the PC.
- ↪ Download the configuration software from the Internet to the PC (see chapter 6.2.1 "Downloading configuration software").  
Unpack the installation package.
- ↪ Start the *SensorStudioSetup.exe* file.
- ↪ Follow the instructions on the screen.

The Installation Wizard installs the software and places a shortcut on the desktop ()

### 6.2.3 Installing the communication DTM and the device DTM

Prerequisites:

- ✓ A FDT frame is installed on the PC.
- ↪ Start the *LeAnalysisCollection.exe* file from the installation package and follow the instructions on the screen.

The installation wizard installs communication DTM and device DTM for DCR 50.

### 6.2.4 Connecting device to PC

The device is connected to the PC via the RS 232 interface.

- You need an RS 232 connection that establishes the RxD, TxD and GND connections between PC and device (see chapter 5.4 "PC or terminal connection").
- The 5 V DC voltage supply is to be fed in externally (see chapter 5.1 "Voltage supply").

**NOTICE**

 The MA-CR modular adapter unit with spring terminals and plug connector for connecting the device, as well as a D-SUB 9-pin socket for connecting an RS 232 interconnection cable, is available as an accessory (see chapter 13 "Order guide and accessories").

The MA-CR modular adapter unit requires 10 V ... 30 V DC as external voltage supply, which can be fed in via spring terminals. Alternatively, 5 V DC can be fed via the 6-pin plug connector of the DCR 50 using a 150 mm long interconnection cable with 12-pin Molex terminal strip.

### 6.3 Starting the Sensor Studio configuration software

Prerequisites:

- The device has been mounted (see chapter 4 "Mounting") and connected (see chapter 5 "Electrical connection") correctly.
- The device is connected to the PC via the RS 232 interface (see chapter 6.2.4 "Connecting device to PC").
- The *Sensor Studio* configuration software is installed on the PC (see chapter 6.2 "Installing Sensor Studio configuration software").

↪ Start the *Sensor Studio* configuration software by double-clicking the *Sensor Studio* icon (). The **mode selection** of the **Project Wizard** is displayed.

↪ Select the **Device selection without communication connection (offline)** configuration mode and click on [Next].

The **Project Wizard** displays the **Device selection** list of the configurable devices.

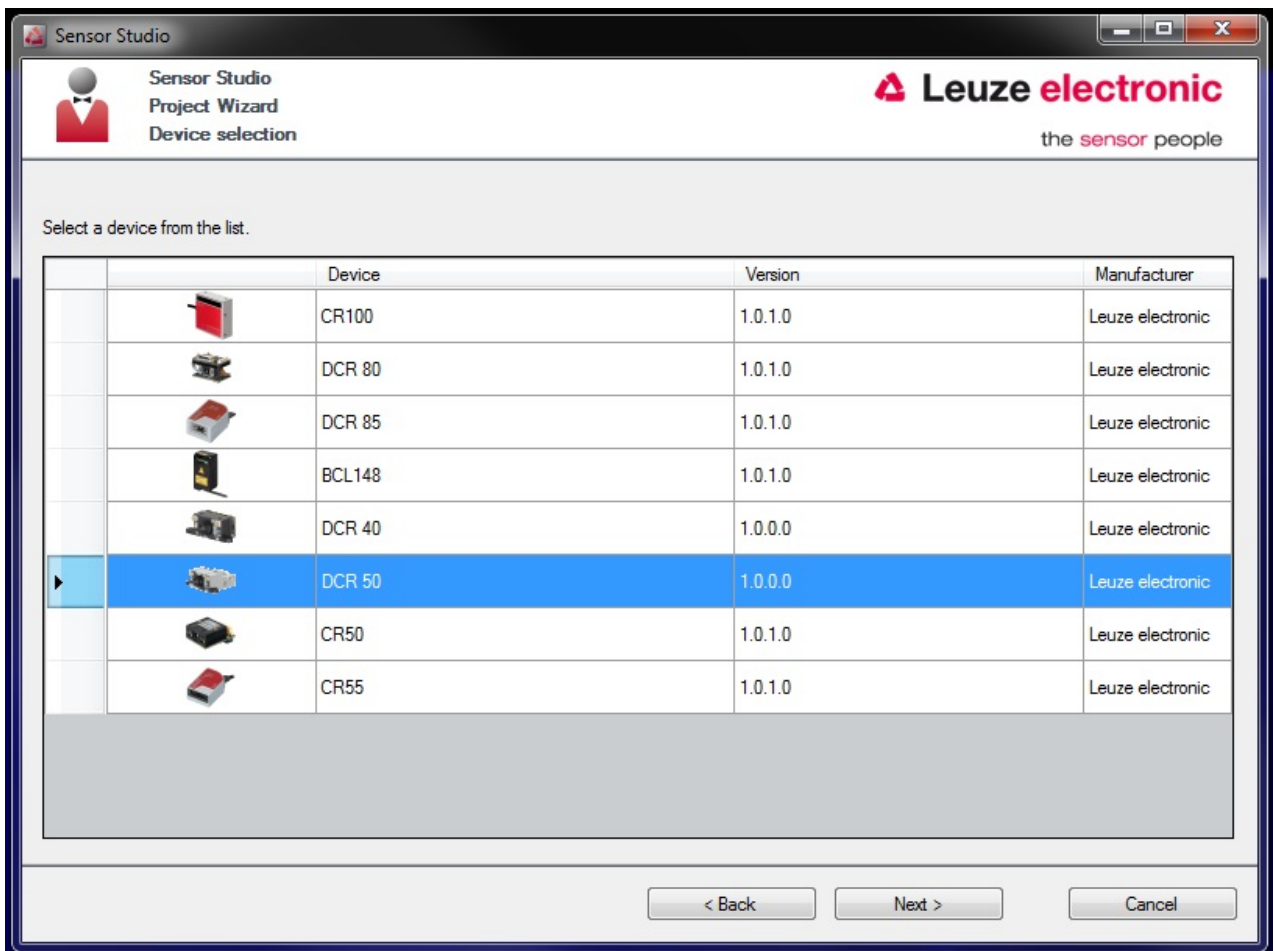

Fig. 6.1: Device selection for scan engine DCR 50

- ↪ Select **DCR 50** in the **Device selection** and click on [Next].  
The device manager (DTM) of the connected DCR 50 starts with the offline view for the *Sensor Studio* configuration project.
  - ↪ Establish the online connection to the connected DCR 50.  
In the *Sensor Studio* FDT frame, click on the [Establish connection with device] button (▶).  
In the *Sensor Studio* FDT frame, click on the [Upload parameters to device] button (⬆).
- The current configuration data is displayed in the device manager (DTM).

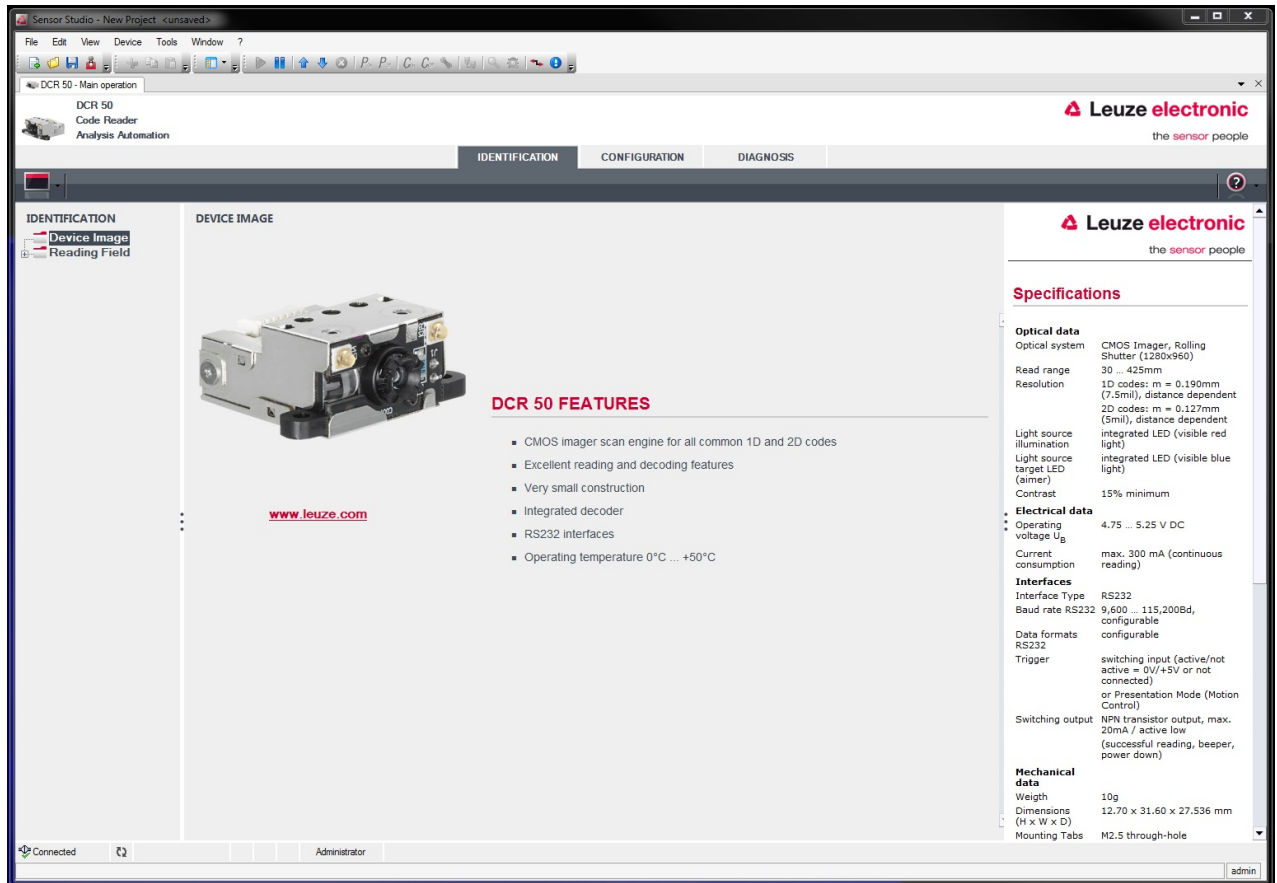

Fig. 6.2: Configuration project: Sensor Studio device manager (DTM) for DCR 50

- ↪ The menus of the *Sensor Studio* device manager (DTM) can be used to change or read out the configuration of the connected device.  
The user interface of the *Sensor Studio* device manager (DTM) is largely self-explanatory. The online help system provides information on the menu items and adjustment parameters. Select the **Help** menu item in the menu [?] (🔍).
- ↪ Transfer the modified configuration parameters to the device.  
If a connection exists, click on the [Download parameters to device] button (⬇) on the task bar.

## 6.4 Exiting Sensor Studio

After completing the configuration settings, close the *Sensor Studio* configuration software.

- ↪ Exit the program via **File > Exit**.
- ↪ Save the configuration settings as a configuration project on the PC.

You can open the configuration project again at later time via **File > Open** or with the *Sensor Studio* Project Wizard (🔧).

## 6.5 Configuration parameters

In this chapter, you will find information and explanations on the configuration parameters of the device manager (DTM).

**NOTICE**

 This chapter does not include a complete description of the *Sensor Studio* configuration software. Complete information on the FDT frame menu and on the functions in the device manager (DTM) can be found in the online help system.

The device manager (DTM) of the *Sensor Studio* configuration software offers the following configuration functions:

- *General (Control)*
- *Decode* (see chapter 6.5.2 "Decode tab")
- *Communications* (see chapter 6.5.3 "Communications tab")
- *Diagnosis* (see chapter 6.5.4 "Diagnosis / Terminal")

**NOTICE**

 The online help system displays information on the menu items and configuration parameters for each function. Select the **Help** menu item in the menu [?].

### 6.5.1 Control tab

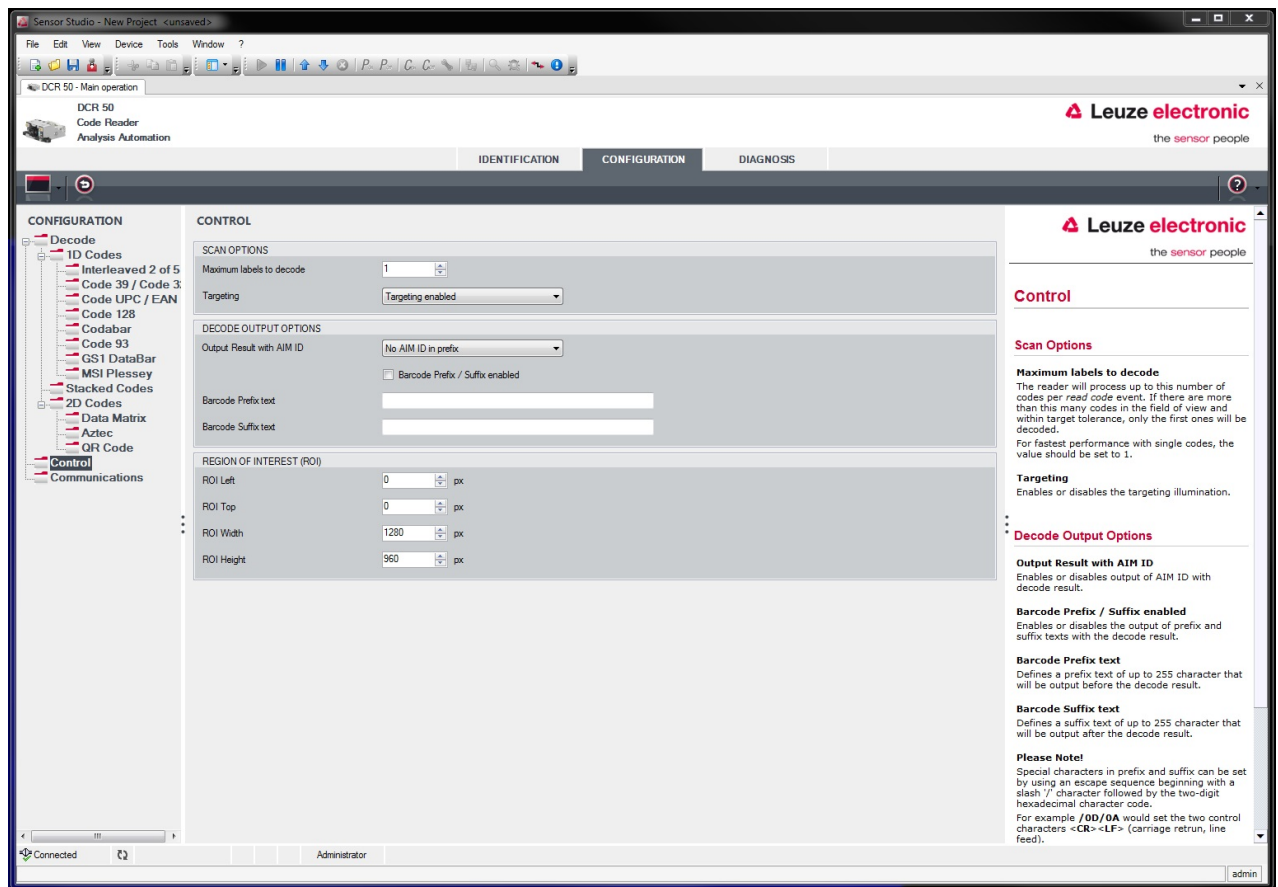

Fig. 6.3: Control tab

SCAN OPTIONS	
Maximum labels to decode	The device processes up to this number of codes per <i>read code</i> event. <ul style="list-style-type: none"> <li>• If there are more codes in the field of view and within target tolerance and the device is set to decode more than one code, it will decode all codes in the field of view.</li> <li>• Set to 1 for fastest performance with single codes.</li> </ul>
Targeting	Switch the blue targeting LED on and off.
DECODE OUTPUT OPTIONS	
Output Result with AIM ID	Allows for the output of the AIM symbology identifier with the decode result.
Barcode Prefix / Suffix enabled	Enables/ disables the output of prefix and suffix text with the decode result.
Barcode Prefix text Barcode Suffix text	Defines text of up to 255 characters that is added before/after the decode result.
REGION OF INTEREST (ROI)	
ROI Left ROI Top ROI Width ROI Height	Allows for setting the region of interest in the image where the labels are decoded.

6.5.2 Decode tab

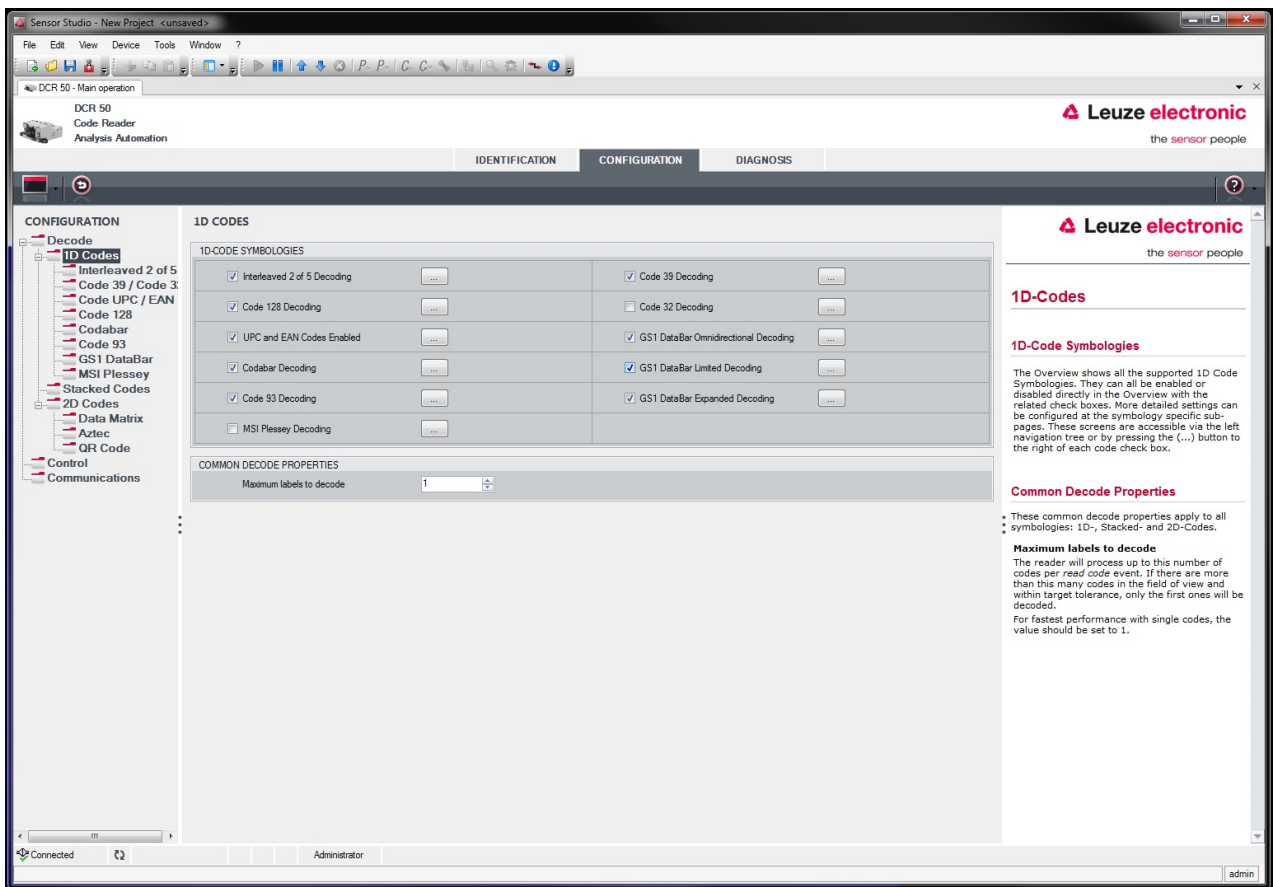

Fig. 6.4: Decode tab

<p>SYMBOLOLOGIES</p>	<p>Use the ... button to the right of the given code to select the code-specific settings.</p> <p>Alternatively, the property settings can be selected directly via the navigation tree under the Decode button.</p> <p>The properties can be individually set for each code type.</p>
<p>COMMON DECODE PROPERTIES</p>	<p>Maximum labels to decode</p> <p>The device processes up to this number of codes per <i>read code</i> event.</p> <ul style="list-style-type: none"> <li>• If there are more codes in the field of view and within target tolerance and the device is set to decode more than one code, it will decode all codes in the field of view.</li> <li>• Set to 1 for fastest performance with single codes.</li> </ul>

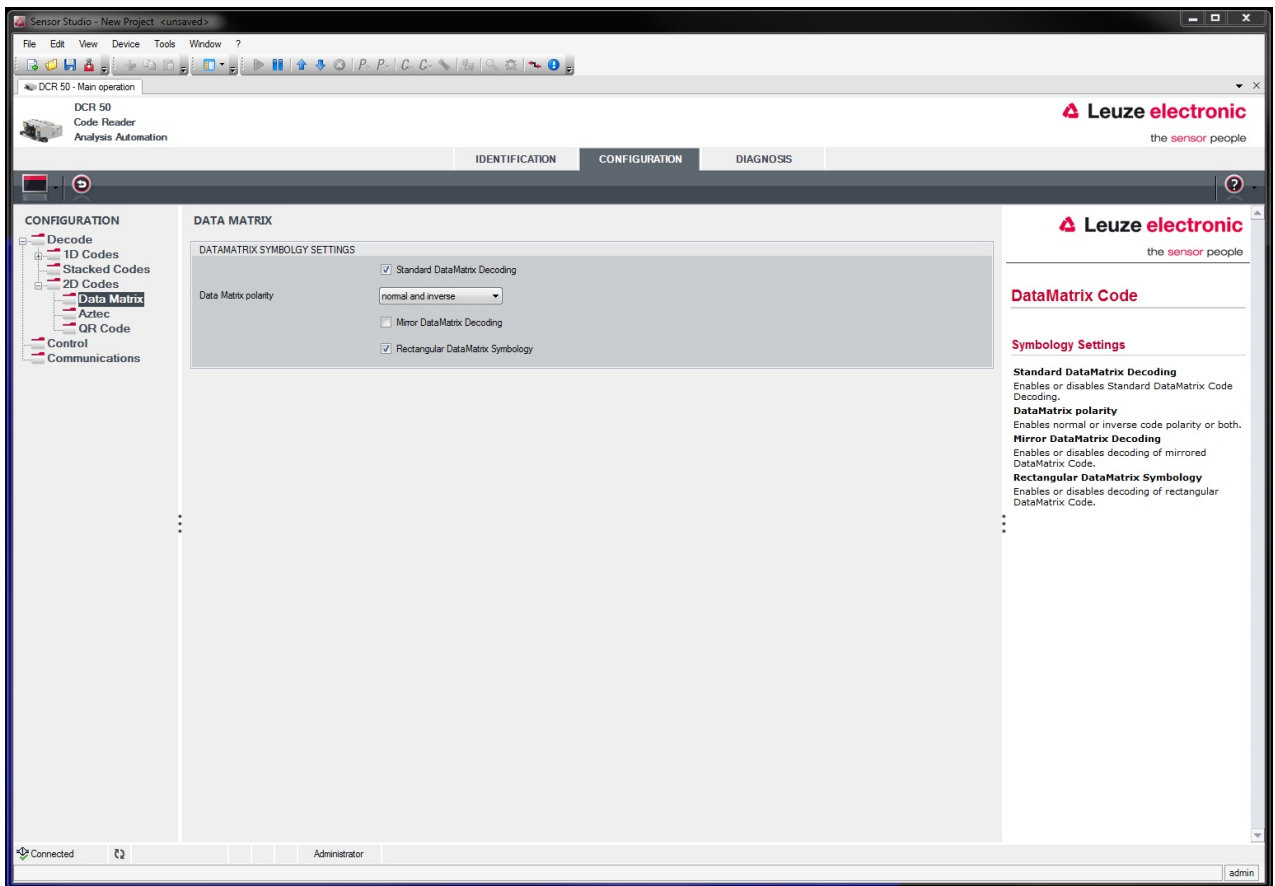

Fig. 6.5: Standard settings for the Properties window (SYMBOLY SETTINGS) – Decode tab

6.5.3 Communications tab

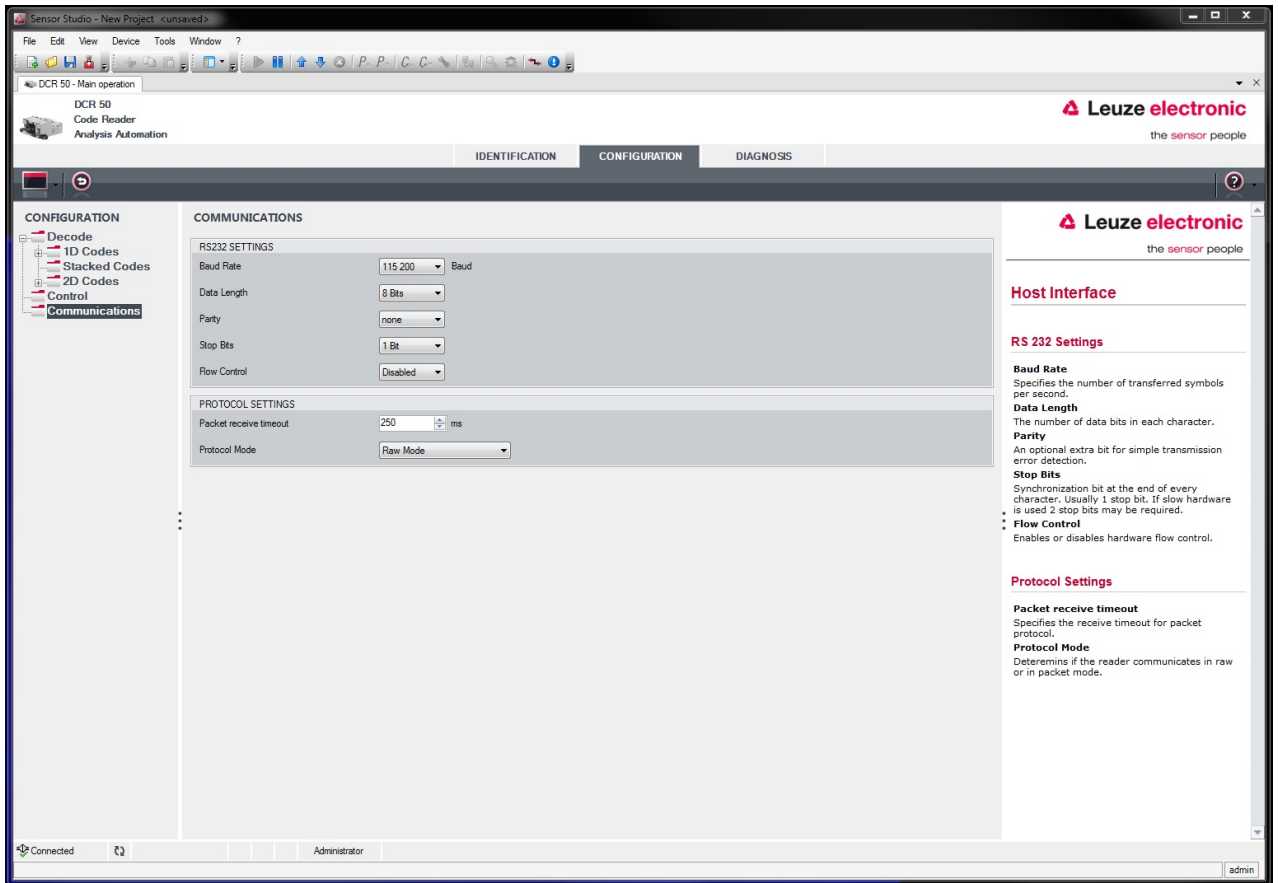

Fig. 6.6: Communications tab

Select the desired baud rate, the stop bits, the data bits, the parity and various transmission modes here. The desired acknowledgment settings are also to be set in this selection window.

6.5.4 Diagnosis / Terminal

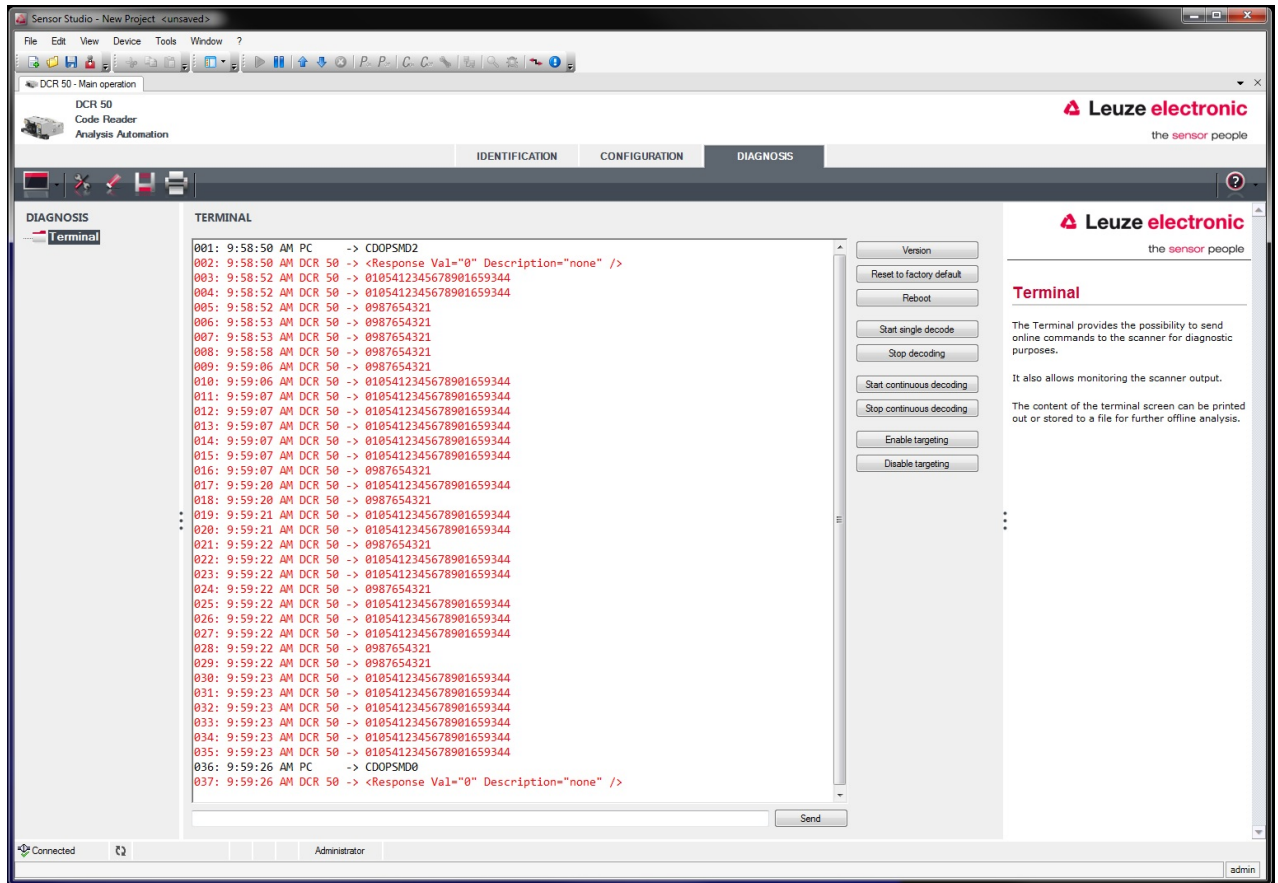

Fig. 6.7: Terminal

The Terminal tab provides the following functions:

- Send online commands to the scan engine for diagnostic purposes.
- Visualize the output of the scan engine.

The contents of the terminal display can be printed out or saved in a file for subsequent offline evaluation.

## 7 Starting up the device - Configuration

### 7.1 Measures to be performed prior to the initial commissioning

NOTICE	
	<ul style="list-style-type: none"><li>↳ Please observe the notices for device arrangement, see chapter 4.1 "Selecting a mounting location".</li><li>↳ If possible, always trigger the scanner with the aid of commands or an external signal transmitter (photoelectric sensor).</li><li>↳ Before commissioning, familiarize yourself with the operation and configuration of the device(s).</li><li>↳ Before connecting the supply voltage, recheck all connections and ensure that they have been properly made.</li></ul>

### 7.2 Starting the device

#### 7.2.1 Interface

Proper function of the interface can be most easily tested in service operation using the serial interface with the Sensor Studio configuration software and a notebook computer.

#### 7.2.2 Online commands

Using the online commands, important device functions can be checked, e.g. reading activation.

#### 7.2.3 Problems

If a problem occurs that cannot be rectified even after checking all electrical connections and settings on the devices and on the host, contact your responsible Leuze electronic subsidiary or Leuze electronic customer service, see chapter 11 "Service and support".

### 7.3 Setting the communication parameters

You have now commissioned the device. Usually, you will have to configure it before you can use it. Using the configuration options offered in the *Sensor Studio* or by means of the device DTM, the device can be individually configured according to your application. For information on the various configuration options, see chapter 6 "Configuration and diagnostics software - Sensor Studio" or refer to the online help.

It is normally sufficient to set the code type and code length in accordance with the 1D or 2D codes that are to be read in order to be able to operate the device.

The setting of code type and code length is usually accomplished by using the *Sensor Studio* configuration software (see chapter 6 "Configuration and diagnostics software - Sensor Studio").

## 8 Configuration control

This chapter specifies the configuration commands of the scan engine.

### Notations

The interface protocol is described as a set of grammars, indicated by different type styles and symbols.

Example	Indication	Grammar
<i>Text-Command</i>	Italic type	Syntactic categories (non-terminals)
<b>space</b>	Bold type	Terminal symbols
%xx	Byte data	In Hex
0xFF	0x prefix indicating hexadecimal	Literal byte values
'X'	Single quotes	Literal ASCII characters
SOH	All caps	Non-printable ASCII characters
esc   tab	Vertical bar	Alternatives (this or that)
data <sub>opt</sub>	opt. (opt subscript)	Optional terminals and non-terminals
crc16 <sub>nr</sub>	nr (nr subscript)	Applies to packets sent in non-raw mode, i. e. in packet mode

### 8.1 Configuration command architecture

This section describes the format of configuration commands that the scan engine will accept to change and save configuration settings.

#### Command format

Primary category	Sub-category	Action code (SP/R/G)	Parameter	Parameter value (when actions is S or P)
Example: SY, CM, etc.	Example: AZTC, SE, etc.	S – Change and save P – Change but do not save R – Reset to default value G – Get value in effect	Example: AL, BA, [, etc.	String of decimal number or text

#### Example: SYAZTCSP01

This command sets the polarity to Inverse mode of the Aztec symbology and saves it to non-volatile memory. Breakdown of the command:

- SY = Symbology
- AZTC = Aztec
- S = Set
- PO = Polarity
- 1 = Inverse Mode

**Example: SYAZTCSP01,MR1**

This compound command sets the polarity to Inverse mode of the Aztec symbology and sets the ability to read mirrored Aztec codes. It saves both to non-volatile memory. Breakdown of the command:

- SY = Symbology
- AZTC = Aztec
- S = Set
- PO = Polarity
- 1 = Inverse Mode
- MR = Mirror
- 1 = Enable

**8.2 Supported commands**

**8.2.1 Symbology**

Code Description	Command Format Options				De- fault	Notes/Examples	
Get All Symbology Parameters	SY	ALLS	G			Returns all Symbology values in a single XML element <b>Example:</b> SYALLSG	
Australian Post – Get All Parameter	SY	AUP O	G			Returns all Australian post parameter values in an XML element. <b>Example:</b> SYAUPOG	
Australian Post	SY	AUP O	S/P/R/ G	EN	0	0	Disable <b>Example:</b> SYAUPOSEN0
						1	Enable <b>Example:</b> SYAUPOSEN1
Australian Post – Strip Checksum	SY	AUP O	S/P/R/ G	SC	0	0	Disable <b>Example:</b> SYAUPOSSC0
						1	Enable <b>Example:</b> SYAUPOSSC1
						This setting value is ignored if Australian Post decoding is disabled.	
Aztec – Get All Parameter	SY	AZT C	G			Returns all Aztec parameter values in an XML element. <b>Example:</b> SYAZTCG	
Aztec	SY	AZT C	S/P/R/ G	EN	1	0	Disable <b>Example:</b> SYAZTCSEN0
						1	Enable Example: SYAZTCSEN1

Code Description	Command Format Options				De- fault	Notes/Examples	
Aztec – Polarity	SY	AZT C	S/P/R/ G	PO	0	0	Normal mode enabled - Black on white background <b>Example:</b> SYAZTCSP00
						1	Inverse mode enabled - White on black background <b>Example:</b> SYAZTCSP01
						2	Both normal and inverse modes enabled <b>Example:</b> SYAZTCSP02
						<b>Note:</b> This setting value is ignored if Aztec decoding is disabled	
Aztec – Mirror	SY	AZT C	S/P/R/ G	MR	0	0	Disable <b>Example:</b> SYAZTCSMR0
						1	Enable Example: SYAZTCSMR1
						The ability to decode an Aztec code that has been printed as a mirror image of a standard Aztec. <b>Note:</b> This setting value is ignored if Aztec decoding is disabled.	
BC412 – Get All Parameter	SY	B412	G			Returns all BC412 parameter values in an XML element. <b>Example:</b> SYB412G	
BC412	SY	B412	S/P/R/ G	EN	0	0	Disable <b>Example:</b> SYB412SEN0
						1	Enable Example: SYB412SEN1
BC412 – Reverse Decoding	SY	B412	S/P/R/ G	RD	0	0	Disable <b>Example:</b> SYB412SRD0
						1	Enable Example: SYB412SRD1
						The ability to decode a BC412 that is printed in reverse. <b>Note:</b> This setting value is ignored if BC412 decoding is disabled.	
Canada Post	SY	CAP O	S/P/R/ G	EN	0	0	Disable <b>Example:</b> SYCAPOSEN0
						1	Enable Example: SYCAPOSEN1
Codabar – Get All Parameter	SY	CBA R	G			Returns all Codabar parameter values in an XML element. <b>Example:</b> SYCBARG	

Code Description	Command Format Options				De- fault	Notes/Examples	
Codabar	SY	CBA R	S/P/R/ G	EN	1	0	Disable <b>Example:</b> SYCBARSEN0
						1	Enable Example: SYCBARSEN1
Codabar – Require Checksum	SY	CBA R	S/P/R/ G	CS	0	0	Disable checksum check and output checksum if one exists. <b>Example:</b> SYCBARSCS0
						1	Enable checksum check and output checksum. <b>Example:</b> SYCBARSCS1
						2	Enable checksum check and strip checksum. <b>Example:</b> SYCBARSCS2
						<b>Note:</b> This setting value is ignored if Codabar decoding is disabled.	
Codabar – Strip Start/ Stop Characters	SY	CBA R	S/P/R/ G	SS	0	0	Disable <b>Example:</b> SYCBARSSS0
						1	Enable <b>Example:</b> SYCBARSSS1
						<b>Note:</b> This setting value is ignored if Codabar decoding is disabled	
Codablock A	SY	COD A	S/P/R/ G	EN	0	0	Disable <b>Example:</b> SYCODASEN0
						1	Enable <b>Example:</b> SYCODASEN1
Codablock F	SY	COD F	S/P/R/ G	EN	0	0	Disable <b>Example:</b> SYCODFSEN0
						1	Enable <b>Example:</b> SYCODFSEN1
Code 11 – Get All Parameter	SY	CO1 1	G			Returns all code 11 parameter values in an XML element. <b>Example:</b> SYBCO11G	
Code 11	SY	CO1 1	S/P/R/ G	EN	0	0	Disable <b>Example:</b> SYCO11SEN0
						1	Enable <b>Example:</b> SYCO11SEN1

Code Description	Command Format Options				De- fault	Notes/Examples	
Code 11 – Checksum Off / 1-digit / 2-digit	SY	CO1 1	S/P/R/ G	CS	2	0	Decode with checksum disabled <b>Example:</b> SYCO11SCS0
						1	Decode with one checksum digits checked. <b>Example:</b> SYCO11SCS1
						2	Decode with two checksum digits checked. <b>Example:</b> SYCO11SCS2
						<b>Note:</b> This setting value is ignored if Code 11 decoding is disabled.	
Code 11 – Strip Checksum Characters On/Off	SY	CO1 1	S/P/R/ G	SC	0	0	Disable <b>Example:</b> SYCO11SSC0
						1	Enable <b>Example:</b> SYCO11SSC1
						<b>Note:</b> This setting value is ignored if Code 11 decoding is disabled.	
Code 32	SY	CO3 2	S/P/R/ G	EN	0	0	Disable <b>Example:</b> SYCO32SEN0
						1	Enable <b>Example:</b> SYCO32SEN1
Code 39 – Get All Parameter	SY	CO3 9	G			Returns all Code 39 parameter values in an XML element. <b>Example:</b> SYCO39G	
Code 39	SY	CO3 9	S/P/R/ G	EN	1	0	Disable <b>Example:</b> SYCO39SEN0
						1	Enable <b>Example:</b> SYCO39SEN1
Code 39 – Checksum Off/On/On Strip Check Character	SY	C039	S/P/R/ G	CS	0	0	Disables checksum check & output checksum if one exists <b>Example:</b> SYCO39SCS0
						1	Enables checksum check and output checksum <b>Example:</b> SYCO39SCS1
						2	Enables checksum check and strip checksum from decode data. <b>Example:</b> SYCO39SCS2
						<b>Note:</b> This setting value is ignored if Code 39 decoding is disabled.	
Code 39 – Extended ASCII On/Off	SY	CO3 9	S/P/R/ G	EA	0	0	Disable <b>Example:</b> SYCO39SEA0
						1	Enable <b>Example:</b> SYCO39SEA1
						<b>Note:</b> This setting value is ignored if Code 39 decoding is disabled.	

Code Description	Command Format Options				De- fault	Notes/Examples	
Code 39 – Start Stop On/Off	SY	CO3 9	S/P/R/ G	SS	0	0	Disable <b>Example:</b> SYCO39SSS0
						1	Enable <b>Example:</b> SYCO39SSS1
						<b>Note:</b> This setting value is ignored if Code 39 decoding is disabled	
Code 49	SY	CO4 9	S/P/R/ G	EN	1/0	0	Disable <b>Example:</b> SYCO49SEN0
						1	Enable <b>Example:</b> SYCO49SEN1
Code 93	SY	CO9 3	S/P/R/ G	EN	1	0	Disable <b>Example:</b> SYCO93SEN0
						1	Enable <b>Example:</b> SYCO93SEN1
Code 128	SY	C128	S/P/R/ G	EN	1	0	Disable <b>Example:</b> SYC128SEN0
						1	Enable <b>Example:</b> SYC128SEN1
Composite	SY	COM P	S/P/R/ G	EN	0	0	Disable <b>Example:</b> SYCOMPSEN0
						1	Enable <b>Example:</b> SYCOMPSEN1
Data Matrix – Get All Parameter	SY	DAT M	G			Returns all Data matrix parameter values in an XML element. <b>Example:</b> SYDATMG	
Data Matrix	SY	DAT M	S/P/R/ G	EN	1	0	Disable <b>Example:</b> SYDATMSEN0
						1	Enable <b>Example:</b> SYDATMSEN1
Data Matrix – Polarity	SY	DAT M	S/P/R/ G	PO	2	0	Normal mode enabled - Black on white background <b>Example:</b> SYDATMSPO0
						1	Inverse mode enabled - White on black background <b>Example:</b> SYDATMSPO1
						2	Both normal and inverse modes enabled <b>Example:</b> SYDATMSPO2
						<b>Note:</b> This setting value is ignored if Data Matrix decoding is disabled.	

Code Description	Command Format Options				De- fault	Notes/Examples	
Data Matrix – Mirror	SY	DAT M	S/P/R/ G	MR	0	0	Disable <b>Example:</b> SYDATMSMR0
						1	Enable <b>Example:</b> SYDATMSMR1
						<b>Note:</b> This setting value is ignored if Data Matrix decoding is disabled.	
Data Matrix Rectangular	SY	DAT M	S/P/R/ G	RE	1	0	Disable <b>Example:</b> SYDATMSRE0
						1	Enable <b>Example:</b> SYDATMSRE1
						<b>Note:</b> This setting value is ignored if Data Matrix decoding is disabled	
Data Matrix Rectangular Extended	SY	DAT M	S/P/R/ G	RX	0	0	Disable <b>Example:</b> SYDATMSRX0
						1	Enable <b>Example:</b> SYDATMSRX1
						<b>Note:</b> This setting value is ignored if Data Matrix decoding is disabled	
Grid Matrix – Get All Parameter	SY	GDM X	G			Returns all Grid Matrix parameter values in an XML element. <b>Example:</b> SYGDMXG	
Grid Matrix	SY	GDM X	S/P/R/ G	EN	0	0	Disable <b>Example:</b> SYGDMXSEN0
						1	Enable <b>Example:</b> SYGDMXSEN1
Grid Matrix – Polarity	SY	GDM X	S/P/R/ G	PO	1	0	Normal mode enabled - Black on white background <b>Example:</b> SYGDMXSPO0
						1	Inverse mode enabled - White on black background <b>Example:</b> SYGDMXSPO1
						2	Both normal and inverse modes enabled <b>Example:</b> SYGDMXSPO2
						<b>Note:</b> This setting value is ignored if Grid Matrix decoding is disabled.	
Grid Matrix – Mirror	SY	GDM X	S/P/R/ G	MR	0	0	Disable <b>Example:</b> SYGDMXSMR0
						1	Enable <b>Example:</b> SYGDMXSMR1
						<b>Note:</b> This setting value is ignored if Grid Matrix decoding is disabled.	
GS1 DataBar – Get All Parameter	SY	GS1 D	G			Returns all GS1 DataBar parameter values in an XML element. <b>Example:</b> SYGS1DG	

Code Description	Command Format Options				Default	Notes/Examples	
GS1 DataBar	SY	GS1 D	S/P/R/ G	EN	1	0	Disable <b>Example:</b> SYGS1DSEN0
						1	Enable <b>Example:</b> SYGS1DSEN1
GS1 DataBar Omnidirectional & truncated	SY	GS1 D	S/P/R/ G	OT	0	0	Disable <b>Example:</b> SYGS1DSOT0
						1	Enable <b>Example:</b> SYGS1DSOT1
GS1 DataBar Stacked	SY	GS1 D	S/P/R/ G	ST	1	0	Disable <b>Example:</b> SYGS1DSST0
						1	Enable <b>Example:</b> SYGS1DSST1
GS1 DataBar Expanded	SY	GS1 D	S/P/R/ G	EX	1	0	Disable <b>Example:</b> SYGS1DSEX0
						1	Enable <b>Example:</b> SYGS1DSEX1
GS1 DataBar Expanded Stacked	SY	GS1 D	S/P/R/ G	ES	1	0	Disable <b>Example:</b> SYGS1DSES0
						1	Enable <b>Example:</b> SYGS1DSES1
GS1 DataBar Limited	SY	GS1 D	S/P/R/ G	LI	1	0	Disable <b>Example:</b> SYGS1DSL10
						1	Enable <b>Example:</b> SYGS1DSL11
Han Xin – Get All Parameter	SY	HAX N	G				Returns all Han Xin parameter values in an XML element. <b>Example:</b> SYHAXNG
Han Xin	SY	HAX N	S/P/R/ G	EN	0	0	Disable <b>Example:</b> SYHAXNSEN0
						1	Enable <b>Example:</b> SYHAXNSEN1
Han Xin – Polarity	SY	HAX N	S/P/R/ G	PO	0	0	Normal mode enabled - Black on white background <b>Example:</b> SYHAXNSPO0
						1	Inverse mode enabled - White on black background <b>Example:</b> SYHAXNSPO1
						2	Both normal and inverse modes enabled <b>Example:</b> SYHAXNSPO2
						<b>Note:</b> This setting value is ignored if Han Xin decoding is disabled	

Code Description	Command Format Options				De- fault	Notes/Examples	
Han Xin – Mirror	SY	HAX N	S/P/R/ G	MR	0	0	Disable <b>Example:</b> SYHAXNSMR0
						1	Enable <b>Example:</b> SYHAXNSMR1
						<b>Note:</b> This setting value is ignored if Han Xin decoding is disabled	
Hong Kong 2 of 5	SY	H2O 5	S/P/R/ G	EN	0	0	Disable <b>Example:</b> SYH2O5SEN0
						1	Enable <b>Example:</b> SYH2O5SEN1
Interleaved 2 of 5– Get All Parameter	SY	I2O5	G			Returns all Interleaved 2 of 5 parameter values in an XML element. <b>Example:</b> SYI2O5G	
Interleaved 2 of 5	SY	I2O5	S/P/R/ G	EN	1	0	Disable <b>Example:</b> SYI2O5SEN0
						1	Enable <b>Example:</b> SYI2O5SEN1
Interleaved 2 of 5 – Checksum Options Off/ On/Strip Checksum Characters	SY	I2O5	S/P/R/ G	CO	0	0	Disables checksum checking and output checksum if one exists. <b>Example:</b> SYI2O5SCO0
						1	Enables checksum checking and output checksum with decode data. <b>Example:</b> SYI2O5SCO1
						2	Enables checksum check and strip checksum from decode data. <b>Example:</b> SYI2O5SCO2
						<b>Note:</b> This setting value is ignored if Interleaved 2 of 5 decoding is disabled.	
Interleaved 2 of 5 – Length	SY	I2O5	S/P/R/ G	LN	0	0	Minimum Value <b>Example:</b> SYI2O5SLN0
						100	Maximum Value <b>Example:</b> SYI2O5SLN100
						<b>Note:</b> This setting value is ignored if Interleaved 2 of 5 decoding is disabled.	
Japan Post	SY	JAP O	S/P/R/ G	EN	0	0	Disable <b>Example:</b> SYJAPOSEN0
						1	Enable <b>Example:</b> SYJAPOSEN1
KIX (Dutch Post)	SY	KIX0	S/P/R/ G	EN	0	0	Disable <b>Example:</b> SYKIX0SEN0
						1	Enable <b>Example:</b> SYKIX0SEN1

Code Description	Command Format Options				Default	Notes/Examples	
Korean Post	SY	KOP O	S/P/R/ G	EN	0	0	Disable <b>Example:</b> SYKOPOSEN0
						1	Enable <b>Example:</b> SYKOPOSEN1
Matrix 2 of 5	SY	M2O 5	S/P/R/ G	EN	0	0	Disable <b>Example:</b> SYM2O5SEN0
						1	Enable <b>Example:</b> SYM2O5SEN1
Maxicode	SY	MAX C	S/P/R/ G	EN	0	0	Disable <b>Example:</b> SYMAXCSEN0
						1	Enable <b>Example:</b> SYMAXCSEN1
MSI Plessey – Get All Parameter	SY	MSIP	G			Returns all MSI Plessey parameter values in an XML element. <b>Example:</b> SYMSIPG	
MSI Plessey	SY	MSIP	S/P/R/ G	EN	0	0	Disable <b>Example:</b> SYMSIPSEN0
						1	Enable <b>Example:</b> SYMSIPSEN1
MSI Plessey – Require Checksum	SY	MSIP	S/P/R/ G	CS	0	0	Disable <b>Example:</b> SYMSIPSCS0
						1	Enable <b>Example:</b> SYMSIPSCS1
						2	10/10 Checksum type <b>Example:</b> SYMSIPSCS2
						3	11/10 Checksum type <b>Example:</b> SYMSIPSCS3
						<b>Note:</b> This setting value is ignored if MSI Plessey decoding is disabled.	
MSI Plessey – Strip Checksum	SY	MSIP	S/P/R/ G	SC	0	0	Disable <b>Example:</b> SYMSIPSSC0
						1	Enable <b>Example:</b> SYMSIPSSC1
						<b>Note:</b> This setting value is ignored if MSI Plessey decoding is disabled.	
Plessey – PLE	SY	MSIP	S/P/R/ G	PE	0	0	Disable <b>Example:</b> SYMSIPSPE0
						1	Enable <b>Example:</b> SYMSIPSPE1
NEC 2 of 5 – Get All Parameter	SY	N2O 5	G			Returns all NEC 2 of 5 parameter values in an XML element. <b>Example:</b> SYN2O5G	

Code Description	Command Format Options				De- fault	Notes/Examples	
NEC 2 of 5	SY	N2O 5	S/P/R/ G	EN	0	0	Disable <b>Example:</b> SYN2O5SEN0
						1	Enable <b>Example:</b> SYN2O5SEN1
NEC 2 of 5 – Require Checksum	SY	N2O 5	S/P/R/ G	CS	0	0	Disable <b>Example:</b> SYN2O5SCS0
						1	Enable <b>Example:</b> SYN2O5SCS1
						<b>Note:</b> This setting value is ignored if NEC 2 of 5 decoding is disabled.	
PDF417	SY	P417	S/P/R/ G	EN	1	0	Disable <b>Example:</b> SYP417SEN0
						1	Enable <b>Example:</b> SYP417SEN1
Micro PDF417	SY	P417	S/P/R/ G	MI	0	0	Disable <b>Example:</b> SYP417SMI0
						1	Enable <b>Example:</b> SYP417SMI1
Pharma Code – Get All Parameter	SY	PHC O	G			Returns all Pharma code parameter val- ues in an XML element. <b>Example:</b> SYPHCOG	
Pharmacode	SY	PHC O	S/P/R/ G	EN	0	0	Disable <b>Example:</b> SYPHCOSEN0
						1	Enable <b>Example:</b> SYPHCOSEN1
Pharmacode – Reverse	SY	PHC O	S/P/R/ G	RV	0	0	Disable <b>Example:</b> SYPHCO SRV0
						1	Enable <b>Example:</b> SYPHCO SRV1
						<b>Note:</b> This setting value is ignored if Pharmacode decoding is disabled.	
Pharmacode – Support Color bars	SY	PHC O	S/P/R/ G	CB	0	0	Disable <b>Example:</b> SYPHCO SCB0
						1	Enable <b>Example:</b> SYPHCO SCB1
						<b>Note:</b> This setting value is ignored if Pharmacode decoding is disabled.	
Pharmacode – Bar Count Min	SY	PHC O	S/P/R/ G	CN	4	4	Minimum Value <b>Example:</b> SYPHCO SCN4
						<b>Note:</b> This setting value is ignored if Pharmacode decoding is disabled.	

Code Description	Command Format Options				De- fault	Notes/Examples	
Pharmacode – Bar Count Max	SY	PHC O	S/P/R/ G	CX	16	16	Maximum Value <b>Example:</b> SYPHCOSCX16
						<b>Note:</b> This setting value is ignored if Pharmacode decoding is disabled	
Pharmacode – Min Value	SY	PHC O	S/P/R/ G	MI	15	15	Minimum Value <b>Example:</b> SYPHCOSMI15
						<b>Note:</b> This setting value is ignored if Pharmacode decoding is disabled.	
Pharmacode – Max Value	SY	PHC O	S/P/R/ G	MX	131070	131070	Maximum Value <b>Example:</b> SYPHCOSMX131070
						<b>Note:</b> This setting value is ignored if Pharmacode decoding is disabled.	
QR Code – Get All Parameter	SY	QRC O	G			Returns all QR code parameter values in an XML element. <b>Example:</b> SYQRCOG	
QR Code	SY	QRC O	S/P/R/ G	EN	1	0	Disable <b>Example:</b> SYQRCOSEN0
						1	Enable <b>Example:</b> SYQRCOSEN1
QR Code – Polarity	SY	QRC O	S/P/R/ G	PO	0	0	Normal mode enabled - Black on white background <b>Example:</b> SYQRCOSPO0
						1	Inverse mode enabled - White on black background <b>Example:</b> SYQRCOSPO1
						2	Both normal and inverse modes enabled <b>Example:</b> SYQRCOSPO2
						<b>Note:</b> This setting value is ignored if QR code decoding is disabled.	
Micro QR Code	SY	QRC O	S/P/R/ G	MI	0	0	Disable <b>Example:</b> SYQRCOSMI0
						1	Enable <b>Example:</b> SYQRCOSMI1
QR Code – Mirror	SY	QRC O	S/P/R/ G	MR	0	0	Disable <b>Example:</b> SYQRCOSMR0
						1	Enable <b>Example:</b> SYQRCOSMR1
						<b>Note:</b> This setting value is ignored if QR Code decoding is disabled.	

Code Description	Command Format Options				De- fault	Notes/Examples	
QR Code – Mode 1	SY	QRC O	S/P/R/ G	M1	0	0	Disable <b>Example:</b> SYQRCOSM10
						1	Enable <b>Example:</b> SYQRCOSM11
						<b>Note:</b> This setting value is ignored if QR Code decoding is disabled.	
QR Code – Custom	SY	QRC O	S/P/R/ G	CQ	0	0	Disable <b>Example:</b> SYQRCOSCQ0
						1	Enable <b>Example:</b> SYQRCOSCQ1
						<b>Note:</b> This setting value is ignored if QR Code decoding is disabled.	
Straight 2 of 5	SY	S2O5	S/P/R/ G	EN	0	0	Disable <b>Example:</b> SYS2O5SEN0
						1	Enable <b>Example:</b> SYS2O5SEN1
Telepen – Get All Parameter	SY	TELP	G			Returns all Telepen parameter values in an XML element. <b>Example:</b> SYTELPG	
Telepen	SY	TELP	S/P/R/ G	EN	0	0	Disable <b>Example:</b> SYTELPSEN0
						1	Enable <b>Example:</b> SYTELPSEN1
Telepen – Ouput ASCII	SY	TELP	S/P/R/ G	OA	0	0	Disable <b>Example:</b> SYTELPSEA0
						1	Enable <b>Example:</b> SYTELPSEA1
						<b>Note:</b> This setting value is ignored if Telepen decoding is disabled.	
Trioptic – Get All Parameter	SY	TRIO	G			Returns all Trioptic parameter values in an XML element. <b>Example:</b> SYTRIOG	
Trioptic	SY	TRIO	S/P/R/ G	EN	0	0	Disable <b>Example:</b> SYTRIOSEN0
						1	Enable <b>Example:</b> SYTRIOSEN1
Trioptic – Reverse	SY	TRIO	S/P/R/ G	RV	0	0	Disable <b>Example:</b> SYTRIOSRV0
						1	Enable <b>Example:</b> SYTRIOSRV1
						<b>Note:</b> This setting value is ignored if Trioptic decoding is disabled.	

Code Description	Command Format Options				De- fault	Notes/Examples	
Trioptic – Start/Stop	SY	TRIO	S/P/R/ G	SS	0	0	Disable <b>Example:</b> SYTRIOSS0
						1	Enable <b>Example:</b> SYTRIOSS1
						<b>Note:</b> This setting value is ignored if Trioptic decoding is disabled.	
UK Royal Mail	SY	UKR O	S/P/R/ G	EN	0	0	Disable <b>Example:</b> SYUKROSEN0
						1	Enable <b>Example:</b> SYUKROSEN1
						<b>Note:</b> This setting value is ignored if UK Royal Mail decoding is disabled.	
UK Royal Mail – Require Check Character	SY	UKR O	S/P/R/ G	CC	0	0	Disable <b>Example:</b> SYUKROSCC0
						1	Enable <b>Example:</b> SYUKROSCC1
						<b>Note:</b> This setting value is ignored if UK Royal Mail decoding is disabled.	
UPC/EAN – Get All Parameter	SY	UPC 0	G			Returns all UPC/EAN parameter values in an XML element. <b>Example:</b> SYUPC0G	
UPC/EAN	SY	UPC 0	S/P/R/ G	EN	1/0	0	Disable <b>Example:</b> SYUPC0SEN0
						1	Enable <b>Example:</b> SYUPC0SEN1
						<b>Note:</b> This setting value is ignored if UPC/EAN decoding is disabled.	
UPC/EAN – Expand UPC-E to UPC-A	SY	UPC 0	S/P/R/ G	EA	1	0	Disable <b>Example:</b> SYUPC0SEA0
						1	Enable <b>Example:</b> SYUPC0SEA1
						<b>Note:</b> This setting value is ignored if UPC/EAN decoding is disabled.	
UPC/EAN – Supplemental	SY	UPC 0	S/P/R/ G	SU	0	0	Disable <b>Example:</b> SYUPC0SSU0
						1	Enable <b>Example:</b> SYUPC0SSU1
						<b>Note:</b> This setting value is ignored if UPC/EAN decoding is disabled.	
UPC/EAN – Expand EAN-8 to EAN-13	SY	UPC 0	S/P/R/ G	8D	0	0	Disable <b>Example:</b> SYUPC0S8D0
						1	Enable <b>Example:</b> SYUPC0S8D1
						<b>Note:</b> This setting value is ignored if UPC/EAN decoding is disabled.	

Code Description	Command Format Options				De- fault	Notes/Examples	
UPC/EAN – Expand UPC-A to EAN-13	SY	UPC 0	S/P/R/ G	AD	0	0	Disable <b>Example:</b> SYUPC0SAD0
						1	Enable <b>Example:</b> SYUPC0SAD1
						<b>Note:</b> This setting value is ignored if UPC/EAN decoding is disabled.	
UPC/EAN – Convert Bookland EAN-13 to ISBN	SY	UPC 0	S/P/R/ G	DI	0	0	Disable <b>Example:</b> SYUPC0SDI0
						1	Enable <b>Example:</b> SYUPC0SDI1
						<b>Note:</b> This setting value is ignored if UPC/EAN decoding is disabled.	
UPC/EAN – Convert Bookland EAN-13 to ISSN	SY	UPC 0	S/P/R/ G	DN	0	0	Disable <b>Example:</b> SYUPC0SDN0
						1	Enable <b>Example:</b> SYUPC0SDN1
						<b>Note:</b> This setting value is ignored if UPC/EAN decoding is disabled.	
UPC/EAN – Transmit UPC-A Checksum	SY	UPC 0	S/P/R/ G	AC	0	0	Disable <b>Example:</b> SYUPC0SAC0
						1	Enable <b>Example:</b> SYUPC0SAC1
						<b>Note:</b> This setting value is ignored if UPC/EAN decoding is disabled.	
UPC/EAN – Transmit UPC-A Number System	SY	UPC 0	S/P/R/ G	AN	0	0	Disable <b>Example:</b> SYUPC0SAN0
						1	Enable <b>Example:</b> SYUPC0SAN1
						<b>Note:</b> This setting value is ignored if UPC/EAN decoding is disabled.	
UPC/EAN – Transmit UPC-E Checksum	SY	UPC 0	S/P/R/ G	EC	0	0	Disable <b>Example:</b> SYUPC0SEC0
						1	Enable <b>Example:</b> SYUPC0SEC1
						<b>Note:</b> This setting value is ignored if UPC/EAN decoding is disabled.	
UPC/EAN – Transmit UPC-E Number System	SY	UPC 0	S/P/R/ G	ES	0	0	Disable <b>Example:</b> SYUPC0SES0
						1	Enable <b>Example:</b> SYUPC0SES1
						<b>Note:</b> This setting value is ignored if UPC/EAN decoding is disabled.	

Code Description	Command Format Options				De-fault	Notes/Examples	
UPC/EAN – Transmit EAN-13 Checksum	SY	UPC 0	S/P/R/ G	DC	0	0	Disable <b>Example:</b> SYUPC0SDC0
						1	Enable <b>Example:</b> SYUPC0SDC1
						<b>Note:</b> This setting value is ignored if UPC/EAN decoding is disabled.	
UPC/EAN – Transmit EAN-8 Checksum	SY	UPC 0	S/P/R/ G	8C	0	0	Disable <b>Example:</b> SYUPC0S8C0
						1	Enable <b>Example:</b> SYUPC0S8C1
						<b>Note:</b> This setting value is ignored if UPC/EAN decoding is disabled.	
UPC/EAN – Send AIM Modifier	SY	UPC 0	S/P/R/ G	AM	0	0	Disable <b>Example:</b> SYUPC0SAM0
						1	Enable <b>Example:</b> SYUPC0SAM1
USPS Planet	SY	USP L	S/P/R/ G	EN	0	0	Disable <b>Example:</b> SYUSPLSEN0
						1	Enable <b>Example:</b> SYUSPLSEN1
USPS Postnet	SY	USP O	S/P/R/ G	EN	0	0	Disable <b>Example:</b> SYUSPOSEN0
						1	Enable <b>Example:</b> SYUSPOSEN1
UPU ID Tags	SY	UPUI	S/P/R/ G	EN	0	0	Disable <b>Example:</b> SYUPUISEN0
						1	Enable <b>Example:</b> SYUPUISEN1
USPS Intelligent Mail	SY	USIM	S/P/R/ G	EN	0	0	Disable <b>Example:</b> SYUSIMSEN0
						1	Enable <b>Example:</b> SYUSIMSEN1

8.2.2 Communications

Code Description	Command Format Options				De- fault	Notes/Examples	
Get All Communications Parameters	CM	CM	G			Example: CMCMG	
Communications Mode	CM	MO	S/P/R/ G	CM	UK	SE	RS-232 Serial <b>Example:</b> CMMOSCMSE
						UK	USB Keyboard <b>Example:</b> CMMOSCMUK
						UV	USB VCOM <b>Example:</b> CMMOSCMUV
						UN	USB Native <b>Example:</b> CMMOSCMUN
						UP	USB HID POS <b>Example:</b> CMMOSCMUP
						UC	USB CDC VCOM <b>Example:</b> CMMOSCMUC
Communication Protocol	CM	CP	S/P/R/ G	PM	0	0	Raw Mode <b>Example:</b> CMCPSPM0
						1	Packet Mode <b>Example:</b> CMCPSPM1
Connection Retry Timeout (s)	CM	GE	S/P/R/ G	CR	5000	If reader disconnects, it will try to reconnect after the timeout interval in seconds. Valid Range: <b>Example:</b> CMGESCR5000	
RS-232 Interface – Get All parameters	CM	SE	G			Returns all serial communication parameter values in an XML element. <b>Example:</b> CMSEG	
RS-232 Interface – Baud Rate	CM	SE	S/P/R/ G	BA	115200	1200	1200 Bits per second <b>Example:</b> CMSESBA1200
						2400	2400 Bits per second <b>Example:</b> CMSESBA2400
						4800	4800 Bits per second <b>Example:</b> CMSESBA4800
						9600	9600 Bits per second <b>Example:</b> CMSESBA9600
						19200	19200 Bits per second <b>Example:</b> CMSESBA19200
						38400	38400 Bits per second <b>Example:</b> CMSESBA38400
						57600	57600 Bits per second <b>Example:</b> CMSESBA57600
						115200	115200 Bits per second <b>Example:</b> CMSESBA115200
						Supported Baud Rate	

Code Description	Command Format Options				Default	Notes/Examples	
RS-232 Interface – Data Bits	CM	SE	S/P/R/G	DB	8	7	Seven data bits <b>Example:</b> CMSESDB7
						8	Eight data bits Example: CMSESDB8
						The number of bits per character	
RS-232 Interface – Stop Bits	CM	SE	S/P/R/G	SB	1	1	One stop bit <b>Example:</b> CMSESSB1
						2	Two stop bits <b>Example:</b> CMSESSB2
						The number of stop bits sent	
RS-232 Interface – Parity	CM	SE	S/P/R/G	PA	N	N	None – No parity bits <b>Example:</b> CMSESPAN
						E	Even parity bit <b>Example:</b> CMSESPAE
						O	Odd parity bit <b>Example:</b> CMSESPAO
						A parity bit, or check bit, is a bit added to a string of binary code to ensure that the total number of 1-bits in the string is even or odd.	
RS-232 Interface – Flow Control	CM	SE	S/P/R/G	FC	0/1	0	<b>Example:</b> CMSESFC0
						1	<b>Example:</b> CMSESFC1
						Transmit flow control	
RS-232 Interface – Signal Polarity	CM	SE	S/P/R/G	PO	0	0	Standard or non-inverted UART0 signals <b>Example:</b> CMSESPO0
						1	Invert UART0 signals <b>Example:</b> CMSESPO1
						<b>Note:</b> UART1 does not have polarity control <b>Note:</b> The default polarity is controlled by the STRAP[3] value at power up.	

### 8.2.3 USB and HID

Tab. 8.1: USB and HID

Code Description	Command Format Options				Default	Notes/Examples
USB – Get All parameters	CM	UB	G			Returns all USB communication parameter values in an XML element. <b>Example:</b> CMUBG
USB – Manufacturer	CM	UB	S/P/R/G	MF	CODE	A string representing the manufacturer name for the product <b>Example:</b> CMUBSMFCODE

Code Description	Command Format Options				Default	Notes/Examples	
USB – Part Number	CM	UB	S/P/R/G	PN	CR8200	A string representing the part number or name for the product <b>Example:</b> CMUBSPNCR8200	
USB – Full Speed	CM	UB	S/P/R/G	FS	0	0	Disable Full Speed <b>Example:</b> CMUBSFS0
						1	Enable Full Speed <b>Example:</b> CMUBSFS1
HID Keyboard – Get All parameters	CM	HD	G			Returns all HID Keyboard parameter values in an XML element. <b>Example:</b> CMHDG	
HID Keyboard – Inter Character Delay (ms)	CM	HD	S/P/R/G	IC	0	In Milliseconds <b>Valid Range:</b> <b>Example:</b> CMHDSIC4	
HID Keyboard – Inter Scan Delay (ms)	CM	HD	S/P/R/G	IS	0	In Milliseconds <b>Valid Range:</b> <b>Example:</b> CMHDSIS4	
HID Keyboard – Release Delay (ms)	CM	HD	S/P/R/G	RL	0	In Milliseconds <b>Valid Range:</b> <b>Example:</b> CMHDSRL4	
HID Keyboard Control Characters	CM	HD	S/P/R/G	CC	0	0	Use language <b>Example:</b> CMHDSCC0
						1	Use Ctrl+<char> <b>Example:</b> CMHDSCC1
						2	Use Alt+<Keypad> <b>Example:</b> CMHDSCC2
						3	Use Alt+0<Keypad> <b>Example:</b> CMHDSCC3
						How to handle character values in the range 0x00 to 0x1F	
HID Keyboard Decode Data Input Conversion	CM	HD	S/P/R/G	IE	0	0	ASCII – No Conversion <b>Example:</b> CMHDSIE0
						1	ASCII to Unicode Code point <b>Example:</b> CMHDSIE1
						2	UTF-8 to Unicode Code point <b>Example:</b> CMHDSIE2
HID Keyboard Decode Data Output Method	CM	HD	S/P/R/G	OM	0	0	Unicode as XML Lookup <b>Example:</b> CMHDSOM0
						1	Unicode as Windows Alt-Sequence <b>Example:</b> CMHDSOM1
						<b>Note:</b> This parameter is only relevant when Input Conversion > 0	

Code Description	Command Format Options				Default	Notes/Examples	
HID Keyboard Windows code page for Extended ASCII Characters	CM	HD	S/P/R/G	EA	0	0	Append leading zero (Code page 1232) <b>Example:</b> CMHDSEA0
						1	Do not append leading zero (Code page 437) <b>Example:</b> CMHDSEA1
						Extended ASCII characters [0x80, 0xFF] are output as alt-sequences with or without a leading zero which windows uses to determine whether to display the character from CP1232 or CP437. This only applies when the HID Keyboard Decode Data Output Method is set to Unicode as Windows Alt-Sequence.	
USB Keyboard – Get All parameters	CM	UK	G			Returns all USB Keyboard parameter values in an XML element. <b>Example:</b> CMUKG	
USB Keyboard – Number of Endpoints	CM	UK	S/P/R/G	NE	1	1	One endpoint <b>Example:</b> CMUKSEN1
						2	Two endpoints <b>Example:</b> CMUKSEN2
USB Keyboard – Declaration Wait State	CM	UK	S/P/R/G	EM	0	0	Declare enumeration when addressed <b>Example:</b> CMUKSEM0
						1	Declare enumeration after receipt of output report <b>Example:</b> CMUKSEM1
						2	Declare enumeration after receipt of get report descriptor <b>Example:</b> CMUKSEM2
USB Keyboard – Use Serial Number	CM	UK	S/P/R/G	SN	0/1	0	<b>Example:</b> CMUKSSN0
						1	<b>Example:</b> CMUKSSN1
USB Keyboard – IN Endpoint Polling Interval (µs)	CM	UK	S/P/R/G	IN	1000	Controls the USB HID Keyboard IN Endpoint Polling Interval <b>Example:</b> CMUKSIN1000	
USB Vendor – Use Serial Number	CM	UN	S/P/R/G	SN	0/1	0	<b>Example:</b> CMUNSSN0
						1	<b>Example:</b> CMUNSSN1
USB Vendor – IN Endpoint Polling Interval (µs)	CM	UN	S/P/R/G	IN	1000	Controls the USB HID Vendor IN Endpoint Polling Interval <b>Example:</b> CMUNSIN1000	
USB VCOM – Use Serial Number	CM	UV	S/P/R/G	SN	0/1	0	<b>Example:</b> CMUVSSN0
						1	<b>Example:</b> CMUVSSN1
USB HID POS – Use Serial Number	CM	UP	S/P/R/G	SN	0/1	0	<b>Example:</b> CMUPSSN0
						1	<b>Example:</b> CMUPSSN1

Tab. 8.2: HID language support

Code Description	Command Format Options				De- fault	Notes/Examples	
Get all language parameters	LA	IN	G			Get all language settings Example: LAING	
Active language	LA	IN	S/P/R/ G	AL	USEn- glish_ Win	Active language setting <b>Valid Range:</b> Languages listed by the LAINGIL command <b>Example:</b> LAINGAL	
Get Installed languages list	LA	IN	G	IL		List installed language names <b>Example:</b> LAINGIL	
Control character encoding	CM	HD	S/P/R/ G	CC	0	0	Language Default <b>Example:</b> CMHDSCC0
						1	Control + Character <b>Example:</b> CMHDSCC1
						2	Alt + Keypad <b>Example:</b> CMHDSCC2
						3	Alt + Leading 0 <b>Example:</b> CMHDSCC3
						Choose the control character encoding style.	

### 8.2.4 Packet and protocol parameters

Code Description	Command Format Options				De- fault	Notes/Examples
Packet – Get All parameters	PK	OP	G			Returns all packet parameter values in an XML element. <b>Example:</b> PKOPG
Receive Timeout (ms)	PK	OP	S/P/R/ G	RT	250	When retry count specified and reader doesn't receive the ACK, it will resend the response after the timeout. In milliseconds <b>Valid Range:</b> <b>Example:</b> PKOPSRT250
Connection Protocol Timeout (s)	PK	OP	S/P/R/ G	CT	60	When sending fragmented data in packet mode, this timeout specifies the maximum time between two fragments. Reader cancels the transaction when the timeout expires and it didn't receive new fragmented data. In Seconds <b>Valid Range:</b> <b>Example:</b> PKOPSCT120
Reader Retry Count	PK	OP	S/P/R/ G	RC	0	Number of retries from the reader when no ACK is received from the host. <b>Valid Range:</b> <b>Example:</b> PKOPSRC1

8.2.5 Decoder and general decoding parameters

Code Description	Command Format Options					De- fault	Notes/Examples
Get All Decoder Parameters	CD	CD	G				Returns all decoder parameter values in an XML element. <b>Example:</b> CDCDG
	CD	DP					DPM parameters (Not supported)
Decoder Timing – Get All Parameters	CD	DT	G				Returns all decoder timing parameter values in an XML element. <b>Example:</b> CDDTG
Decode Time Limit (ms)	CD	DT	S/P/R/ G	TL	150/32 0		Time limit (decoder) <b>Example:</b> CDDTSTL150
	CD	DT	S/P/R/ G	TF	30		Timeout Factor <b>Example:</b> CDDTSTF30
Get All Decoder Operational Parameters	CD	OP	G				Returns all decoder operational parameter values in an XML element. <b>Example:</b> CDOPG
Maximum Decodes Per Read	CD	OP	S/P/R/ G	PR	1		The reader will process up to this number of barcodes per read. If there are more barcodes in the field of view and target tolerance, only the first ones will be decoded. Valid Range: 1 to 16 <b>Example:</b> CDOPSPR2
Ensure Region of Interest	CD	OP	S/P/R/ G	RO	0	0	Disable ROI <b>Example:</b> CDOPSR00
						1	Enable ROI <b>Example:</b> CDOPSR01
						Ensure decoded barcoded is always inside the region of interest. When disabled, barcode may be decoded as long as it is partially inside the ROI	
Region of Interest Leftmost pixel	CD	OP	S/P/R/ G	RL	0	ROI Left	
Region of Interest Topmost pixel	CD	OP	S/P/R/ G	RT	0	ROI Top	
Region of Interest width (pixels)	CD	OP	S/P/R/ G	RW	1280	ROI width	
Region of Interest height (pixels)	CD	OP	S/P/R/ G	RH	960	ROI height	
Low Contrast 1D	CD	OP	S/P/R/ G	LC	0	0	Disable Low Contrast <b>Example:</b> CDOPSLC0
						1	Enable Low Contrast <b>Example:</b> CDOPSLC1

Code Description	Command Format Options				De- fault	Notes/Examples	
FOI Zoom	CD	OP	S/P/R/ G	ZR	0	0	Disable FOI Zoom Example: CDOPSZR0
						1	Enable FOI Zoom Example: CDOPSZR1
						Increases the FOI resolution to robustly decode small barcodes when FOI is set to sub-region of the entire FOI. For faster speed, set FOI width * FOI height < 320 * 480.	
Enhance Contrast	CD	OP	S/P/R/ G	EC	0	0	Disable <b>Example:</b> CDOPSEC0
						1	Enable <b>Example:</b> CDOPSEC1
						Enhances image contrast before decoding	
Prefix Decode Results with AIM Symbology Identifiers	CD	OP	S/P/R/ G	PA	0	0	Don't prefix with AIM identifier <b>Example:</b> CDOPSPA0
						1	Prefix decode result with ISO/IEC standard 15424/AIM <b>Example:</b> CDOPSPA1
Security Level (Decoder P_SECURITY_LEVEL)	CD	OP	S/P/R/ G	SE			See decoder API
1D Barcode Aggressiveness	CD	OP	S/P/R/ G	SE	0	0	Most Aggressive <b>Example:</b> CDOPSSE0
						1	Less Aggressive for poorly printed 1D barcodes. <b>Example:</b> CDOPSSE1
						2	Least Aggressive for poorly printed 1D barcodes. <b>Example:</b> CDOPSSE2
						11	Less Aggressive for 1D barcodes with low module size <b>Example:</b> CDOPSSE11
						12	Least Aggressive for 1D barcodes with low module size <b>Example:</b> CDOPSSE12
Decode Attempt Time	CD	OP	S/P/R/ G	AT	0	Attempt Time (Same as sticky time in CR8x) <b>Example:</b> CDOPSAT0	
Stop Decoding on Duplicate	CD	OP	S/P/R/ G	SD	0	Instructs the decoder to stop looking for decodes in the current image when a duplicate is found.	
Prefix with AIM Identifier	CD	OP	S/P/R/ G	PA	0	Prefixes the decode data with the 3-character AIM identifier	

Code Description	Command Format Options				De- fault	Notes/Examples	
Cellphone Enable	CD	OP	S/P/R/ G	CE	0	0	Disable Cellphone reading mode
						1	Enable Cellphone reading mode
Upload Images	CD	OP	S/P/R/ G	DI	0	0	Disable uploading images <b>Example:</b> CDOPPDIO
						1	Enable uploading <b>Example:</b> CDOPPD1
						When Upload Images is set, each image captured by the reader will be sent as a stream of data to the host	
Decode Trigger Mode	CD	OP	S/P/R/ G	MD	0	0	Trigger Mode (default) <b>Example:</b> CDOPSMDO
						1	Motion Detection Mode <b>Example:</b> CDOPSM1
						2	Continuous scan Mode <b>Example:</b> CDOPSM2
						Notes: TBD	
Target Tolerance (percent)	CD	VA	S/P/R/ G	TT	1600	<p>For reader to accept a barcode, it must be within certain distance from the center of the image. The distance is defined as a percentage of the barcode's smaller dimension. For example, with a 10 x 20 mm barcode and a setting of 150 (%), the barcode must be within 15 mm of the center of the image.</p> <p>Any value over 1000 is considered infinite tolerance, and no target checking is performed.</p> <p>Valid Range: 1 to 1000</p> <p><b>Example:</b> CDVASTT1600</p>	
Duplicate Block Time (ms)	CD	VA	S/P/R/ G	BT	0	<p>Consecutive duplicate barcodes (i.e. barcodes that contain the same data) are blocked for this amount of time (in milliseconds). 0 turns off blocking of duplicate barcodes.</p> <p>Valid Range: 0 to xx</p> <p><b>Example:</b> CDVASBT100</p>	
Block Duplicates	CD	VA	S/P/R/ G	BD	0	0	Disable – do not block duplicates <b>Example:</b> CDVASBD0
						1	Enable –block duplicates for the amount of time set in DC-VAGBT <b>Example:</b> CDVASBD1
						If enabled, the reader will not output the same barcode until the barcode has not been seen for the “duplicate block time” period.	

Code Description	Command Format Options				De- fault	Notes/Examples	
Data manipulation format option selection	CD	OP	S/P/R/ G	FO	0	0	Don't format data output <b>Example:</b> CDOPSF00
						1	Format data with prefix/suffix or data configuration string <b>Example:</b> CDOPSF01
						2	Perform match string validation* <b>Example:</b> CDOPSF02
						3	Perform GS1 validation* <b>Example:</b> CDOPSF03
						4	Perform UDI validation <b>Example:</b> CDOPSF04
						5	Perform ISO15434 validation <b>Example:</b> CDOPSF05
						6	Perform ISO15434 & ISO15418 validation <b>Example:</b> CDOPSF06
						7	Perform Simple Age verification using configuration string* <b>Example:</b> CDOPSF07
						8	Perform Simple Age verification without configuration <b>Example:</b> CDOPSF08
						9	Perform DL Parsing with configuration string <b>Example:</b> CDOPSF09
						10	Perform DL Parsing without configuration <b>Example:</b> CDOPSF10
						11	Perform Success & Raw validation <b>Example:</b> CDOPSF11
Simple prefix	CD	OP	S/P/R/ G	PX		Data formatting prefix <b>Example:</b> CDOPSPX	
Simple suffix	CD	OP	S/P/R/ G	SX		Data formatting suffix <b>Example:</b> CDOPSSX	
Output in upper or lower case or bracketed hex bytes	CD	OP	S/P/R/ G	FC		upper	
						lower case	
						hex bytes	
						Data formatting output case/hex <b>Example:</b> CDOPSF0C	
Full data format string	CD	OP	S/P/R/ G	FD		Data formatting raw format configuration string <b>Example:</b> CDOPSF0D	

Code Description	Command Format Options				De- fault	Notes/Examples	
Public sector & validation configuration string	CD	OP	S/P/R/ G	FP		Validation & public sector configuration string <b>Example:</b> CDOPSFP	
Stand Detection	CD	ST	S/P/R/ G	SE	1	0	Disable <b>Example:</b> CDSTSSE0
						1	Enable <b>Example:</b> CDSTSSE1
						Detects when the reader has been placed in a stand that contains a trigger magnet and change to Motion Detection mode.	
	CD	ST	S/P/R/ G	SD		CDSTSSD100	
						Stand detect duplicate barcode block delay in ms	

### 8.2.6 Power mode parameters

Code Description	Command Format Options				De- fault	Notes/Examples	
Get All Power Management Parameters	PM	PM	G			Returns all power management parameter values in an XML element. <b>Example:</b> PMPMG	
Standby Mode Timer	PM	SB	S/P/R/ G	EN	0	0	Disable Standby Mode Timer <b>Example:</b> PMSBSEN0
						1	Enable Standby Mode Timer <b>Example:</b> PMSBSEN1
Standby Mode Timer Delay (ms)	PM	SB	S/P/R/ G	VA	5000	If Standby Mode Timer is enabled, the device will go into Standby Mode after this timer has expired. Valid Range: <b>Example:</b> PMSBSVA2000	
Sleep Mode Timer	PM	SM	S/P/R/ G	EN	0	0	Disable Sleep Mode Timer <b>Example:</b> PMSMSEN0
						1	Enable Sleep Mode Timer <b>Example:</b> PMSMSEN1
						The Standby Mode Timer must be enabled for the device to go into Sleep Mode.	
Sleep Mode Timer Delay (ms)	PM	SM	S/P/R/ G	VA	3600	If both Standby Mode Timer and Sleep Mode Timer are enabled, the device will go into Sleep Mode after this timer has expired. Valid Range: <b>Example:</b> PMSMSVA3600	

Code Description	Command Format Options				De- fault	Notes/Examples	
Sleep Mode Timer – Main- tain Connection	PM	SM	S/P/R/ G	MC	1	0	Disconnect from host in Sleep Mode <b>Example:</b> PMSMSC0
						1	Retain connection in Sleep Mode <b>Example:</b> PMSMSC1
Power Mode Enter Sleep	PM	ES				Forces the device to go into Sleep Mode even if Standby Mode Timer and Sleep Mode Timer are disabled. This command should be sent as RAW. The device will immediately go into Sleep Mode after receiving this command. <b>Example:</b> PMES	

### 8.2.7 General reader information

Code Description	Command Format Options				De- fault	Notes/Examples	
Get All Reader Information Parameters	RD	RD	G			Returns all Reader Information parameter values in an XML element. <b>Example:</b> RDRDG	
Get all Firmware information	RD	FW	G			Returns all Firmware parameter values in an XML element. <b>Example:</b> RDFWG	
Firmware Version Major	RD	FW	G	MJ		Returns Firmware Major Version parameter value in an XML element. <b>Example:</b> RDFWGMJ	
Firmware Version Minor	RD	FW	G	MN		Returns Firmware Minor Version parameter value in an XML element. <b>Example:</b> RDFWGMN	
Firmware Version Build Version	RD	FW	G	BU		Returns Firmware Build Version parameter value in an XML element. <b>Example:</b> RDFWGBU	
Decoder Version	RD	FW	G	DV		Returns Decoder version parameter value in an XML element. <b>Example:</b> RDFWGDV	
Chip Revision	RD	CP	G	RV		Returns Chip Revision parameter value in an XML element <b>Example:</b> RDCPGRV	
Reader Serial Number	RD	CP	G	SN		Returns Reader Serial Number parameter value in an XML element <b>Example:</b> RDCPGSN	
Reader Information	RD	RR	G			Returns Reader Information parameter value in an XML element <b>Example:</b> RDRRG	

Code Description	Command Format Options				De-fault	Notes/Examples
Reader ID	RD	RR	G	ID		Returns Reader ID parameter value in an XML element. <b>Example:</b> RDRRGID
Hardware Revision	RD	RR	G	HR		Returns Reader Hardware Revision parameter value in an XML element. <b>Example:</b> RDRRGHR
Reader Model Type	RD	RR	S/P/R/G	MT	0	DCR 50 <b>Example:</b> RDRRSMT6
Reader Information String	RD	RR	G	IS		Returns Reader Information String parameter value in an XML element. <b>Example:</b> RDRRGIS
Reader Output Format – Line Ending	RD	OF	S/P/R/G	LE	<CR><LF> (%0D%0A)	Defines the output format line ending. Non-printable ASCII characters must be set using URL encoded hex value. <b>Example:</b> RDOFSLE%0D%0A
Reader Command – Process Barcode Data	RD	CM	X	BD	<data>	Sends <data> to the host as barcode data <b>Example:</b> RDCMXBD12345
Reader Command – Reboot	RD	CM	X	RB	1	Reboots the reader <b>Example:</b> RDCMXRB1
Reader Command – Post Event	RD	CM	X	EV		Posts an event. If the event has parameters, it uses P1 and P2. The values for these parameters are specified after each parameter. <b>Example:</b> Posts an event to start a single decode RDCMXEV1, P11, P20
				P1		(see Reader Command List below)
				P2		(see Reader Command List below)
				P3		(see Reader Command List below)
				P4		(see Reader Command List below)
				PL		(see Reader Platform command below)
RDCMX Reader Command Execute List	EV 1	P10				Stop decoding
		P11	P20			Start single decode
		P11	P21			Start continuous decoding
	EV 2	P10				Disable Targeting
		P11				Enable Targeting

Code Description	Command Format Options				De-fault	Notes/Examples
RDCMXPL Reader Command to set a platform configuration			"<Configuration>"			Quoted string containing the Configuration Control Command. The configuration will be saved and restored on reboot/restart. Enclose the command in square brackets (inside the quotes) and add a caret between the opening square bracket and command to delete a command from the platform configuration Save Example: RDCMXPL"FBGRPBI" Delete Example: RDCMXPL"[^FBGRPBI]"
Get All Reader Licenses	RD	LC	G	GL		Returns all Reader License values in an XML element. <b>Example:</b> RDLCGGL
Load License	RD	LC	X	LD	"URL encoded license string"	Loads license on the reader Copies the contents of the License CRB file starting after the '?' character to use as the URL encoded license string. This string must be in quotes in the command. <b>Example:</b> RDLCXLD"%23%45..."
Delete License	RD	LC	X	DL	License number	Deletes a license License number is an integer that represents just the license number, not the serial number of the license you want to delete. <b>Example:</b> RDLCXDL5000

### 8.2.8 Reader configuration

Code Description	Command Format Options				De-fault	Notes/Examples
Get All Reader Parameters	CF		G			Returns all Reader Parameter values in an XML element. Example: CFG
Reset Reader to Factory Default	CF		R			Resets all reader parameters to factory default values. Example: CFR

### 8.2.9 General firmware operation

Code Description	Command Format Options				De-fault	Notes/Examples
Get All Firmware Parameters	FW	FW	G			Returns all Firmware parameter values in an XML element. <b>Example:</b> FWFVG

Code Description	Command Format Options				De- fault	Notes/Examples	
Echo option	FW	CM	S/P/R/ G	OE	0	0	Disable Raw Command Echoing <b>Example:</b> FWCMSE0
						1	Enable Raw Command Echoing <b>Example:</b> FWCMSE1
Raw Command Enable	FW	CM	S/P/R/ G	OR	0	0	Disable Raw Commands <b>Example:</b> FWCMSOR0
						1	Enable Raw commands <b>Example:</b> FWCMSOR1

### 8.2.10 General reader feedback parameters

Code Description	Command Format Options				Default	Notes/Examples	
Get All Reader Feedback Parameters	FB	FB	G			Returns all Reader Feedback parameter values in an XML element. <b>Example:</b> FBFBG	
Good Read Indication – Frequency (Hz)	FB	GR	S/P/R/ G	FQ	2400	Good read beep output frequency. Valid Range: <b>Example:</b> FBGRSFQ2400	
Good Read Indication – Beep Volume (percent)	FB	GR	S/P/R/ G	VO	100	<b>Valid Range:</b> 0 to 100 percent <b>Example:</b> FBGRSVO100	
Good Read Indication – Beep As IO	FB	GR	S/P/R/ G	BI	0	0	Good Read Indication is a frequency output as defined by FB-GRGFQ <b>Example:</b> FBGRSBI0
						1	Good Read Indication is an IO signal <b>Example:</b> FBGRSBI1

### 8.2.11 Setup default AGC mode

Code Description	Command Format Options				Default	Notes/Examples	
Get All Scene Manager Parameters	SC	SC	G			Returns all Scene Manager parameter values in an XML element. <b>Example:</b> SCSCG	
Scene Manager Mode	SC	SP	S/P/R/ G	MO	NO	NO	Normal AGC Mode <b>Example:</b> SCSPSMONO
						BY	Bypass AGC Mode <b>Example:</b> SCSPSMOBY
						FX	Fixed AGC Mode <b>Example:</b> SCSPSMOFX

Code Description	Command Format Options				Default	Notes/Examples
Set Imager Exposure	SC	SP	S/P/R/ G	EX		This defines the imager exposure in Bypass AGC Mode. <b>Example:</b> SCSPSEX50
Set Imager Gain	SC	SP	S/P/R/ G	GN		This defines the imager gain in Bypass AGC Mode. <b>Example:</b> SCSPSGN50
Set Imager Illumination	SC	SP	S/P/R/ G	IL		This defines the Imager Illumination in Bypass AGC Mode. <b>Example:</b> SCSPSIL50
Set Fixed percent (percent)	SC	SP	S/P/R/ G	FP		Set Fixed percent Valid Range: 0 to 100 Example:

### 8.2.12 Setup AGC parameters

Code Description	Command Format Options				De- fault	Notes/Examples
Get All AGC Parameters	AG	AG	G			Returns all AGC parameters values in an XML element. <b>Example:</b> AGAGG
Max AGC Brightness in Motion Detect (percent)	AG	CR	S/P/R/ G	MB	100	Sets the maximum brightness used while in Motion Detect mode. An integer from 0 to 100 representing a percentage of overall maximum brightness. Valid Range: 0 to 100 <b>Example:</b> AGCRPMB50
AGC Timing	AG	TM	S/P/R/ G	HQ	360	AGC High Quality time limit Valid Range: <b>Example:</b> AGTMSHQ360
AGC Medium Quality time limit	AG	TM	S/P/R/ G	MQ	320	AGC Medium Quality time limit Valid Range: <b>Example:</b> AGTMSMQ320
AGC Low Quality time limit	AG	TM	S/P/R/ G	LQ	120	AGC Low Quality time limit Valid Range: <b>Example:</b> AGTMSLQ120
Timeout multiplier (FP24_8)	AG	TM	S/P/R/ G	MT	0x100	Timeout multiplier (FP24_8) Valid Range: <b>Example:</b> AGTMS

8.2.13 Setup motion detection parameters

Code Description	Command Format Op-tions				De-fault	Notes/Examples
Get All motion detect settings	MD	PM	G			Returns all motion detection parameter values in an XML element. <b>Example:</b> MDPMG
Minimum Illumination	MD	PM	S/P/R/G	NI	0	0   Minimum Value
						Minimum illumination is the lowest value the AGC should use to set the illumination. <b>Valid Range:</b> 0 to Maximum illumination <b>Example:</b> MDPMSNI1
Maximum illumination	MD	PM	S/P/R/G	XI	6	100   Maximum Value
						This is the highest value the AGC should use to set the illumination <b>Valid Range:</b> Minimum illumination to 100 <b>Example:</b> MDPMSXI0
Initial illumination value	MD	PM	S/P/R/G	II	1	The starting value the AGC will use to start adjusting illumination <b>Valid Range:</b> Minimum illumination to Maximum illumination <b>Example:</b> MDPMSII1
Minimum exposure time (µs)	MD	PM	S/P/R/G	NE	1	1   Minimum Value
						<b>Valid Range:</b> 1 to Maximum exposure time microseconds <b>Example:</b> MDPMSNE100 This is the minimum time the camera lets light into the element to take the picture in microseconds.
Maximum exposure time (µs)	MD	PM	S/P/R/G	XE	46	20000   Maximum Value
						<b>Valid Range:</b> Minimum exposure time to 20000 microseconds <b>Example:</b> MDPMSXE10040
Initial exposure time (µs)	MD	PM	S/P/R/G	IE	40	<b>Valid Range:</b> Minimum exposure time to Maximum exposure time microseconds <b>Example:</b> MDPMSIE100
Minimum gain	MD	PM	S/P/R/G	NG	1	0   Minimum Value
						<b>Valid Range:</b> 0 to Maximum Gain <b>Example:</b> MDPMSNG15
Maximum gain	MD	PM	S/P/R/G	XG	47	64   Maximum Value
						Gain is the amount of signal amplification the AGC can apply to make the picture easier to read <b>Valid Range:</b> Minimum Gain to 64 <b>Example:</b> MDPMSXG35

Code Description	Command Format Options				De-fault	Notes/Examples
Initial gain	MD	PM	S/P/R/G	IG	21	<p><b>Valid Range:</b> Greater than or equal to Minimum Gain and less than or equal to Maximum Gain.</p> <p><b>Example:</b> MDPMSIG15</p>
Minimum lightest pixel value	MD	PM	S/P/R/G	NL	60	0   Minimum Value
						<p><b>Valid Range:</b> 0 to Maximum lightest pixel value</p> <p><b>Example:</b> MDPMSNL60</p>
Maximum lightest pixel value	MD	PM	S/P/R/G	XL	90	255   Maximum Value
						<p>The lightest values give the motion calculations a base range for maximum brightness before the image begins to saturate. If you set these too high, the algorithm will not be able to detect individual pixels because the image is washed out.</p> <p><b>Valid Range:</b> Minimum lightest pixel value to 255</p> <p><b>Example:</b> MDPMSXL90</p>
Detection pixel threshold	MD	PM	S/P/R/G	PL	15	<p>This pixel threshold is the minimum difference value between the background brightness and the pixel brightness for the current pixel to be considered a pixel.</p> <p>Valid Range:</p> <p><b>Example:</b> MDPMS PL15</p>
Detection total threshold	MD	PM	S/P/R/G	TL	5	<p>Total threshold is the minimum number of pixels detected per detection region (left, center, right) to be considered detected motion</p> <p>Valid Range:</p> <p><b>Example:</b> MDPMS TL5</p>
Detection blob threshold	MD	PM	S/P/R/G	BT	4	<p>The minimum number of sequential pixels to be considered a group or blob (like a bar width)</p> <p>Valid Range:</p> <p><b>Example:</b> MDPMSBT4</p>

8.2.14 Setup camera parameters

Code Description	Command Format Op-tions				De-fault	Notes/Examples		
Test Mode	IM	CP	S/P/R/G	TM		Example: IMCPG		
Minimum Exposure (per-cent)	IM	CP	S/P/R/G	ME	20	<table border="1"> <tr> <td>0</td> <td>Minimum Value</td> </tr> </table> <p>Defines the minimum exposure parameter of camera</p> <p><b>Valid Range:</b> 0 to less than or equal to Maximum Exposure percent</p> <p><b>Example:</b> IMCPSME20</p>	0	Minimum Value
0	Minimum Value							
Maximum Exposure (per-cent)	IM	CP	S/P/R/G	XE	100	<table border="1"> <tr> <td>100</td> <td>Maximum Value</td> </tr> </table> <p><b>Valid Range:</b> Greater than or equal to Minimum Exposure to 100 percent</p> <p><b>Example:</b> IMCPSXE100</p>	100	Maximum Value
100	Maximum Value							

8.2.15 Command barcode format

The scan engine can receive commands directly through user input, via serial or text and via configuration command barcodes. This section describes the format of configuration command barcodes.

Header	Command	Trailer
<SOH>Y<GS><STX> (%01%59%1D%02)	String	<ETX><EOT> (%03%04)

Multiple commands can be included in one configuration command barcode by separating each command with <ETX>.

Example: Scanning a barcode generated from %01%59%1d%02SYAZTCG%03SYAUPOG%03%04 will output all settings of the AZTC and AUPO symbologies.

Configuration command barcodes:

- Configuration command barcodes use the QR code barcode symbology.
- Source files to generate configuration barcodes have a file extension of .CRCCS and an intermediate file extension of .CRMKR.
- If source files contain comments, the comment should start with two forward slash (//) characters.
- Source files can have only one Primary Category command per line (see chapter 8.1 "Configuration command architecture").

Examples:

- example.crccs  
Contains:  
// Hypothetical  
// Outputs all settings of symbologies Aztec and Australian Post  
// Rev 1 – 6/22/16 – Jackson – Initial Release
- example.crmkr  
Contains:  
%01%59%1d%02SYAZTCG%03SYAUPOG%03%04
- example.tif



### 8.3 Motion detection

The scan engine supports motion detection, which means, the device can detect codes brought into the field of view and decode them without manually triggering a decode. Motion detect is often used with the device stationary or mounted, and targets passing in front of it. The device is set to use the minimum internal illumination possible, and works best when in bright ambient light shining from behind the device.

#### Motion detection parameters

The motion detection determination uses many parameters. The exposure time, gain, and illumination are camera settings used to get the best picture to determine whether or not objects have moved into the field of view. They all have minimum and maximum values which the AGC (Automatic Gain Control) uses to get that best picture.

- The exposure is how long the camera “shutter” lets light into the detector array. If it is not open long enough, all the device can see is blackness. If it is open too long, all the pixels are over-exposed, and the picture is white. By setting the minimum and maximum time, the AGC is allowed to open the shutter. We can try to force the AGC to not over- or under-expose the picture.
- The gain is the amount of amplification the AGC can use to attempt to increase the contrast of the picture between light and dark pixels. Setting the minimum too low does not produce enough contrast, and setting the maximum too high overflows the AGC. Thus, the gain range helps the AGC to optimize the contrast of the data without overflowing the calculations.
- The illumination is how much additional light the device shines on the image to increase the sensitivity of the motion detection algorithm. The more illumination, the easier it is to read the codes, however, it also makes the device more obvious in a given environment. By setting the minimum and maximum illumination, the device can be set to add much less light into an environment.
- Thresholds are used to detect motion in the following way:
  - A baseline is created when motion detection starts. Thus, the device has a set of values to compare against.
  - Motion detection finds pixels that vary (more or less) from the baseline by more than the *pixelThreshold* threshold. Motion detection then filters out groups of pixels detected when the number of consecutive pixels is less than the *blobThreshold* threshold, considering it a false positive.
  - When the total number of pixels not filtered out is greater than the total threshold, the device determines that a code has come into the field of view: motion detected.
- The motion detect takes three blocks - a left block, a center block, and a right block - from the complete image from which to detect motion. Motion in any one of the three blocks or in the combined detection from all three blocks causes motion detection.

## 8.4 Data formatting

The scan engine supports data formatting at the decoder level. This produces fast, consistent results in a minimal amount of device space. The device supports simple prefixes and suffixes around the decoded data - the simplest form of data formatting and allows full user control by using the data format string. The device performs data validations and public sector parsing by using the format parse setting in conjunction with the selected format option.

### Data formatting options

The decoder allows many types of data formatting, selected by setting the data format option, and setting the appropriate configuration string.

Tab. 8.3: Data format options

Value	Description
0	Data formatting off
1	Simple data formatting using either prefix and suffix, or by setting the format data string directly.
2	Match String validation
3	GS1 DataBar validation (requires a license)
4	UDI/HIBC validation (requires a license)
5	ISO 15434 validation
6	ISO 15434 and ISO 15418 validation
7	Simple age verification using a configuration string
8	Simple age verification without using a configuration string
9	DL Parsing using a configuration string
10	DL Parsing without using a configuration string
11	Success and Raw validation
<b>Note:</b> Several options require a license	

### Data format string

The data format string allows full user control of the data formatting. The data format string consists of a 12-digit configuration string, typically zeros, a prefix, decode data, and a suffix. Also, there may be user data injected into the string. Format string example that adds a carriage return line feed to the decoded data:

```
CDOPSF0"000000000000!,,/0d/0a"
```

### Prefixes and Suffixes

Prefix and suffix values define data that will be added to the read code data. The firmware adds the prefix and suffix to the beginning and end of the decoded data respectively. Adding prefix or suffix data allows you to define prefixes and/or suffixes and enable/disable them as needed.

- Define the prefix and/or suffix strings:
  - Command to define a prefix: `CDOPSPX"string"`
  - Command to define a suffix: `CDOPSSX"string"`
  - "string" must be in quotes in the command.
  - Non-printable characters are represented by a forward slash and the corresponding hexadecimal value, such as `/0D` for a carriage return.

Examples:

- Command to define a prefix comma: `CDOPSPX", "`
- Command to define a prefix non-keyboard tab: `CDOPSPX"/09"`
- Enable the application of prefixes and suffixes:  
After defining prefix and/or suffix strings, the application of prefixes and suffixes must be enabled.  
Command: `CDOPSF01`

### Format case

The decoder will decode the code data. Setting the format case option changes the default configuration string. You can set the following data output options:

- decoded (0)
- uppercase (1)
- lowercase (2)
- bracketed hex (3)

Example: `CDOPSF01` sets the data output in upper case.

### Format parse and validation configuration string

Validation and public sector parsing also require a configuration string. This string is set using the `CDOPSP"string"` command.

#### NOTICE



Configuration strings and special character sequences are used to enable validation or public sector parsing.

- ↪ Public sector validations and data formatting cannot be used at the same time.
- ↪ When changing from the public sector validations mode to the data formatting mode, you must enter the configuration string again.

## 9 Command protocol

Each device has a well-defined protocol for communication. The protocol can be split into two parts:

- General command/response-type communication
- Barcode decoding

### 9.1 General commands

Most of the time, the user will use the command protocol when communicating with the device. The figure shows the general command sequence for sending a command to the device.

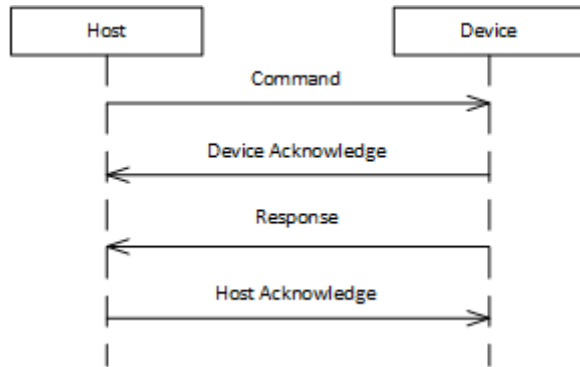

Fig. 9.1: General command sequence

- The host device sends a properly formatted command to the device.
- The device sends an acknowledgement to the host device.
- Immediately after the acknowledgement, the device sends a response to the command.
- To maintain communication integrity, the host device sends an acknowledgement back to the device.

#### 9.1.1 Command packet

To send a command to the device, a properly formatted packet must be formed.

Tab. 9.1: Command packet format

Section	Bytes (or Range)	Number of Bytes	Description
Start of Frame	0x01 0x43 0x54	3	Three bytes that indicate the beginning of a message
Packet Version	0x31	1	Indicates the version number for the packet format. This value is always 0x31.
Packet Length	0x0013 – 0xFFFF	2	Indicates the number of bytes that are sent after these two bytes, up to and including the CRC. This value should be 19+N.  This value is written as a 2-byte big endian value.
Destination Address	0x00000000 – 0xFFFFFFFF	4	Represents the address of the device that you are attempting to communicate with.  0xFFFFFFFF is a special address indicating that the host device wants to broadcast to all devices on the network. Anything less than this value is a real device address.  This value is written as a 4-byte big endian value.

Section	Bytes (or Range)	Number of Bytes	Description
Source Address	0x40000000 – 0x4FFFFFFF	4	Represents the address of the host computer. This value can be any value within the range specified and can be arbitrarily chosen. This value is written as a 4-byte big endian value.
Protocol Type	0x01	1	Indicates the type of protocol to use when communicating. This value is always 0x01.
Flags	0x00		Single byte representing a bit field. For sending a command, this value is always 0x00.
Payload Protocol	0x02	1	Value indicating the type of packet. This value is always 0x02 when sending a command.
Acknowledgement Number	0x0000	2	Represents the acknowledgement number. For a command packet, this value is always 0x0000. This value is written as a 2-byte big endian value.
Transaction Number	0x0000 – 0x7FFF	2	Represents a transaction number for a command. This value is tracked by the host device and is sent to the device as a new command. The host device increments the transaction number by 1. Typically, this value starts at 0x0000 when the device is first powered. This value is written as a 2-byte big endian value.
Request ID	0x8000 – 0xFFFF	2	Represents a unique request ID for this command packet. It is used in the resulting acknowledgement packet. Typically, this value is the transaction number + 0x8000.
Payload		N	Data payload that contains the ASCII command that the host device wants to send to the device.
CRC16	0x0000 – 0xFFFF	2	Represents a CRC16 (using the CCITT zero algorithm) value calculated on the bytes after the packet length. <ul style="list-style-type: none"> <li>• Destination Address</li> <li>• Source Address</li> <li>• Protocol Type</li> <li>• Flags</li> <li>• Payload Protocol</li> <li>• Acknowledgement Number</li> <li>• Transaction Number</li> <li>• Request ID</li> <li>• Payload</li> </ul>

**9.1.2 Device acknowledgement**

Upon receipt of a command, the device immediately sends an acknowledgement.

Tab. 9.2: Acknowledgement packet format

Section	Bytes (or Range)	Number of Bytes	Description
Start of Frame	0x01 0x43 0x54	3	Three bytes that indicate the beginning of a message
Packet Version	0x31	1	Indicates the version number for the packet format. This value is always 0x31.
Packet Length	0xFFFF	2	For an acknowledgement packet, this value is always 15.
Destination Address	0x40000000 – 0x4FFFFFFF	4	Represents the address of the host computer. This value is written as a 4-byte big endian value.
Source Address	0x00000000 – 0x0FFFFFFE	4	Represents the address of the device that you are attempting to communicate with. This value is written as a 4-byte big endian value.
Protocol Type	0x01	1	Indicates the type of protocol to use when communicating. This value is always 0x01.
Flags	0x00		Single byte representing a bit field. For sending a command, this value is always 0x00.
Payload Protocol	0x00	1	Value indicating the type of packet. This value is always 0x00 when sending an acknowledgement.
Acknowledgement Number	0x0000 – 0xFFFF	2	Represents the acknowledgement number. This value is written as a 2-byte big endian value.
CRC16	0x0000 – 0xFFFF	2	Represents a CRC16 (using the CCITT zero algorithm) value calculated on the bytes after the packet length. <ul style="list-style-type: none"> <li>• Destination Address</li> <li>• Source Address</li> <li>• Protocol Type</li> <li>• Flags</li> <li>• Payload Protocol</li> <li>• Acknowledgement Number</li> </ul>

**NOTICE**



The destination address and the source address now have the source address and destination address values from the previous command packet.

- ↳ If a broadcast address is set in the destination address, it is replaced with the address of the device in the corresponding acknowledgement packet.
- ↳ You must use this address in any following sequences. Without using it, the device will not respond.

<b>NOTICE</b>	
	<p>The acknowledgement number in the device acknowledgement packet is the same as the transaction number in the previous command packet.</p>

**9.1.3 Response packet**

After the acknowledgement is sent, the device sends a response to the command. The response packet has the same format as the command packet (see chapter 9.1.1 "Command packet") with the following differences:

- The payload part of the response packet contains the response from the device.
- The transaction number and the request ID are swapped in the response packet (as compared to the command packet).
- The destination address and the source address are swapped in the response packet (as compared to the command packet).

The response is formatted as XML message. Each command description shows an example of a response from each command when getting a value for a setting.

**9.1.4 Host acknowledgement**

After reception of the response packet, the host device must send an acknowledgement packet to the device. This host acknowledgement has the same format as the device acknowledgement (see chapter 9.1.2 "Device acknowledgement") with the following differences:

- The destination address and the source address are swapped in the host acknowledgement packet (as compared to the device acknowledgement packet).
- The acknowledgement number in the host acknowledgement packet is the same as the transaction number in the response packet.

**9.1.5 Example 1: Enabling Code 93 upon startup**

In this example, the host device has just powered the device and is ready to send its first command: make sure Code 93 is enabled.

Assumptions:

- The host device does not know what the address of the device is and thus, will send out a broadcast.
- Address of the host device: 0x40000000
- Address of the device: 0x01234567

Tab. 9.3: Command packet for example 1

Section	Bytes (or Range)	Number of Bytes	Description
Start of Frame	0x01 0x43 0x54	3	
Packet Version	0x31	1	
Packet Length	0x001D	2	19 + 10 = 29 = 0x001D
Destination Address	0x0FFFFFFF	4	Broadcasting to every listening device.
Source Address	0x40000000	4	
Protocol Type	0x01	1	
Flags	0x00		
Payload Protocol	0x02	1	
Acknowledgement Number	0x0000	2	

Section	Bytes (or Range)	Number of Bytes	Description
Transaction Number	0x0000	2	Starting with zero for the transaction number.
Request ID	0x8000	2	Following the convention, we add 0x8000 to the transaction number.
Payload		10	The bytes represent the ASCII command SYCO93PEN1.
CRC16	0x4501	2	

Upon reception of the command, the device sends an acknowledgement.

Tab. 9.4: Device acknowledgement for example 1

Section	Bytes (or Range)	Number of Bytes	Description
Start of Frame	0x01 0x43 0x54	3	
Packet Version	0x31	1	
Packet Length	0x000F	2	
Destination Address	0x40000000	4	
Source Address	0x01234567	4	The device returns its unique address.
Protocol Type	0x01	1	
Flags	0x01		
Payload Protocol	0x00	1	
Acknowledgement Number	0x0000	2	
CRC16	0xED19	2	

After the acknowledgement, the device sends a response packet to the initial command packet.

Tab. 9.5: Response packet for example 1

Section	Bytes (or Range)	Number of Bytes	Description
Start of Frame	0x01 0x43 0x54	3	
Packet Version	0x31	1	
Packet Length	0x003A	2	$19 + 39 = 58 = 0x003A$
Destination Address	0x40000000	4	
Source Address	0x01234567	4	
Protocol Type	0x01	1	
Flags	0x00		
Payload Protocol	0x02	1	
Acknowledgement Number	0x0000	2	
Transaction Number	0x8000	2	

Section	Bytes (or Range)	Number of Bytes	Description
Request ID	0x0000	2	Following the convention, we add 0x8000 to the transaction number.
Payload		39	Returns <Response Val="0" Description="none" />
CRC16	0xDA64	2	

In accordance with the protocol, the host device sends an acknowledgement packet before sending the next command.

Tab. 9.6: Host acknowledgement for example 1

Section	Bytes (or Range)	Number of Bytes	Description
Start of Frame	0x01 0x43 0x54	3	
Packet Version	0x31	1	
Packet Length	0x000F	2	
Destination Address	0x01234567	4	
Source Address	0x40000000	4	
Protocol Type	0x01	1	
Flags	0x01		
Payload Protocol	0x00	1	
Acknowledgement Number	0x8000	2	
CRC16	0x2CCE	2	

### 9.1.6 Example 2: Getting information about a device after startup

In this example, the host device has been communicating with the device for some time and is ready to send another command: enable Code 128 and set it as a default value.

Assumptions:

- Address of the host device: 0x40000000
- Address of the device: 0x01234567

Tab. 9.7: Command packet for example 2

Section	Bytes (or Range)	Number of Bytes	Description
Start of Frame	0x01 0x43 0x54	3	
Packet Version	0x31	1	
Packet Length	0x001D	2	19 + 10 = 29 = 0x001D
Destination Address	0x01234567	4	
Source Address	0x40000000	4	
Protocol Type	0x01	1	

Section	Bytes (or Range)	Number of Bytes	Description
Flags	0x00		
Payload Protocol	0x02	1	
Acknowledgement Number	0x0000	2	
Transaction Number	0x0001	2	
Request ID	0x8000	2	Following the convention, we add 0x8000 to the transaction number.
Payload		10	The bytes represent the ASCII command SYC128PEN1.
CRC16	0x4501	2	

Upon reception of the command, the device sends an acknowledgement.

Tab. 9.8: Device acknowledgement for example 2

Section	Bytes (or Range)	Number of Bytes	Description
Start of Frame	0x01 0x43 0x54	3	
Packet Version	0x31	1	
Packet Length	0x000F	2	
Destination Address	0x40000000	4	
Source Address	0x01234567	4	The device returns its unique address.
Protocol Type	0x01	1	
Flags	0x01		
Payload Protocol	0x00	1	
Acknowledgement Number	0x0001	2	
CRC16	0xFD38	2	

After the acknowledgement, the device sends a response packet to the initial command packet.

Tab. 9.9: Response packet for example 2

Section	Bytes (or Range)	Number of Bytes	Description
Start of Frame	0x01 0x43 0x54	3	
Packet Version	0x31	1	
Packet Length	0x003A	2	19 + 39 = 58 = 0x003A
Destination Address	0x40000000	4	
Source Address	0x01234567	4	
Protocol Type	0x01	1	
Flags	0x00		
Payload Protocol	0x02	1	

Section	Bytes (or Range)	Number of Bytes	Description
Acknowledgement Number	0x0000	2	
Transaction Number	0x8001	2	
Request ID	0x0001	2	
Payload		39	Returns <Response Val="0" Description="none" />
CRC16	0xF213	2	

In accordance with the protocol, the host device sends an acknowledgement packet before sending the next command.

Tab. 9.10: Host acknowledgement for example 2

Section	Bytes (or Range)	Number of Bytes	Description
Start of Frame	0x01 0x43 0x54	3	
Packet Version	0x31	1	
Packet Length	0x000F	2	
Destination Address	0x01234567	4	
Source Address	0x40000000	4	
Protocol Type	0x01	1	
Flags	0x01		
Payload Protocol	0x00	1	
Acknowledgement Number	0x8001	2	
CRC16	0x3CEF	2	

## 9.2 Barcode decoding

The figure shows the command sequence for activating the scan engine for decoding - for a single scan or for continuous scanning.

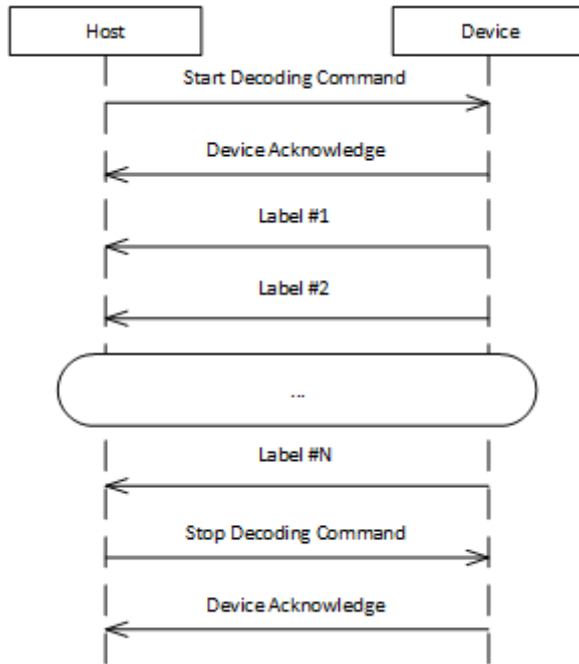

Fig. 9.2: Command sequence for decoding

- The host device sends a start decoding command to the device - for single decode or for continuous decoding
- The device sends the corresponding acknowledgement back to the host device.
- The barcode decoder takes over and sends the barcode result to the host device. The barcode result is sent in clear ASCII text, that is, without the framing protocol.
- The host device sends a stop decoding command to the device.
- The device sends the corresponding acknowledgement back to the host device.

## 10 Care, maintenance and disposal

Usually, the device does not require any maintenance by the operator.

### 10.1 Cleaning

Clean the glass window of the device with a soft cloth before mounting.

#### **NOTICE**



#### **Do not use aggressive cleaning agents!**

↪ Do not use aggressive cleaning agents such as thinner or acetone for cleaning the device.

### 10.2 Servicing

Repairs to the device must only be carried out by the manufacturer.

↪ For repairs, contact your responsible Leuze electronic subsidiary or Leuze electronic customer service (see chapter 11 "Service and support").

### 10.3 Disposing

↪ For disposal observe the applicable national regulations regarding electronic components.

## 11 Service and support

24-hour on-call service at:  
+49 (0) 7021 573-0

Service hotline:  
+49 (0) 7021 573-123  
Monday to Friday 8.00 a.m. to 5.00 p.m. (UTC+1)

E-mail:  
service.identify@leuze.de

Return address for repairs:  
Service center  
Leuze electronic GmbH + Co. KG  
In der Braike 1  
D-73277 Owen / Germany

### 11.1 What to do should servicing be required?

<b>NOTICE</b>	
	<p><b>Please use this chapter as a master copy should servicing be required!</b></p> <p>↳ Enter the contact information and fax the form together with your service order to the fax number given below.</p>

**Customer data (please complete)**

Device type:	
Serial number:	
Firmware:	
Display messages:	
Status of LEDs:	
Error description:	
Company:	
Contact person/department:	
Phone (direct dial):	
Fax:	
Street/No:	
ZIP code/City:	
Country:	

**Leuze Service fax number:**  
+49 (0) 7021 573-199

## 12 Technical data

### 12.1 General specifications

Tab. 12.1: Optics

Optical system	CMOS Imager, Rolling Shutter (1280 x 960)
Reading area	30 mm ... 425 mm
Contrast	1D code: minimum 15 % 2D code: minimum 15 %
Resolution	1D code: m = 0.190 mm (7.5 mil), distance dependent 2D code: m = 0.127 mm (5 mil), distance dependent
Light sources <ul style="list-style-type: none"> <li>• Illumination</li> <li>• Alignment LEDs (Aimer)</li> </ul>	integrated LEDs <ul style="list-style-type: none"> <li>• visible red light</li> <li>• visible blue light</li> </ul>

Tab. 12.2: Code specifications

Code type: 1D	BC412, Codabar, Code 11, Code 32, Code 39, Code 93, Code 128, IATA 2 of 5, Interleaved 2 of 5, GS1 DataBar, Hong Kong 2 of 5, Matrix 2 of 5, MSI Plessey, NEC 2 of 5, Pharmacode, Plessey, Straight 2 of 5, Telepen, Trioptic, UPC/EAN/JAN
Code type: Stacked 1D	Codablock F, Code 49, GS1 Composite (CC-A/CC-B/CC-C), MicroPDF, PDF417
Code type: 2D	Aztec Code, Data Matrix, Han Xin, Micro QR Code, QR Code
Postal Codes	Australian Post, Canada Post, Intelligent Mail, Japan Post, KIX Code, Korea Post, Planet, Postnet, UK Royal Mail, UPU ID Tags

Tab. 12.3: Interfaces

Interface type	RS 232
Baud rate	9600 ... 115200 baud, configurable
Data formats	configurable
Trigger	<ul style="list-style-type: none"> <li>• Switching input                             <ul style="list-style-type: none"> <li>• active: 0 V</li> <li>• inactive: +5 V or not connected</li> </ul> </li> <li>• Presentation Mode (Motion Control)</li> </ul>
Switching output	NPN transistor output, max. 20 mA, Good Read
Buzzer	NPN transistor output, modulated, Good Read

Tab. 12.4: Electrical equipment

Operating voltage	4.75 ... 5.25 V DC
Current consumption	Duration reading: typ. 350 mA Inactive illumination: typ. 75 mA

Tab. 12.5: Mechanical data

Connection type	Molex Inc. (53261-0671), 6-pin
Weight	10 g
Dimensions (H x W x D)	12.70 x 31.60 x 27.53 mm
Fastening	4x M1.8 self-tapping screws, 2 mm deep

Tab. 12.6: Environmental data

Ambient temp. (operation/storage)	0 °C ... +50 °C/-20 °C ... +60 °C
Air humidity	10 % ... 90 % rel. humidity, non-condensing
Ambient light	max. 100000 Lux
Electromagnetic compatibility	EN 55022:2006 Class B IEC 62471:2006
Conformity	CE, FCC, RoHS

## 12.2 Reading fields

### **NOTICE**



Please note that the actual reading fields are also influenced by factors such as labeling material, printing quality, scanning angle, printing contrast etc., and may thus deviate from the reading fields specified here. The origin of the read distance always refers to the front edge of the housing of the beam exit.

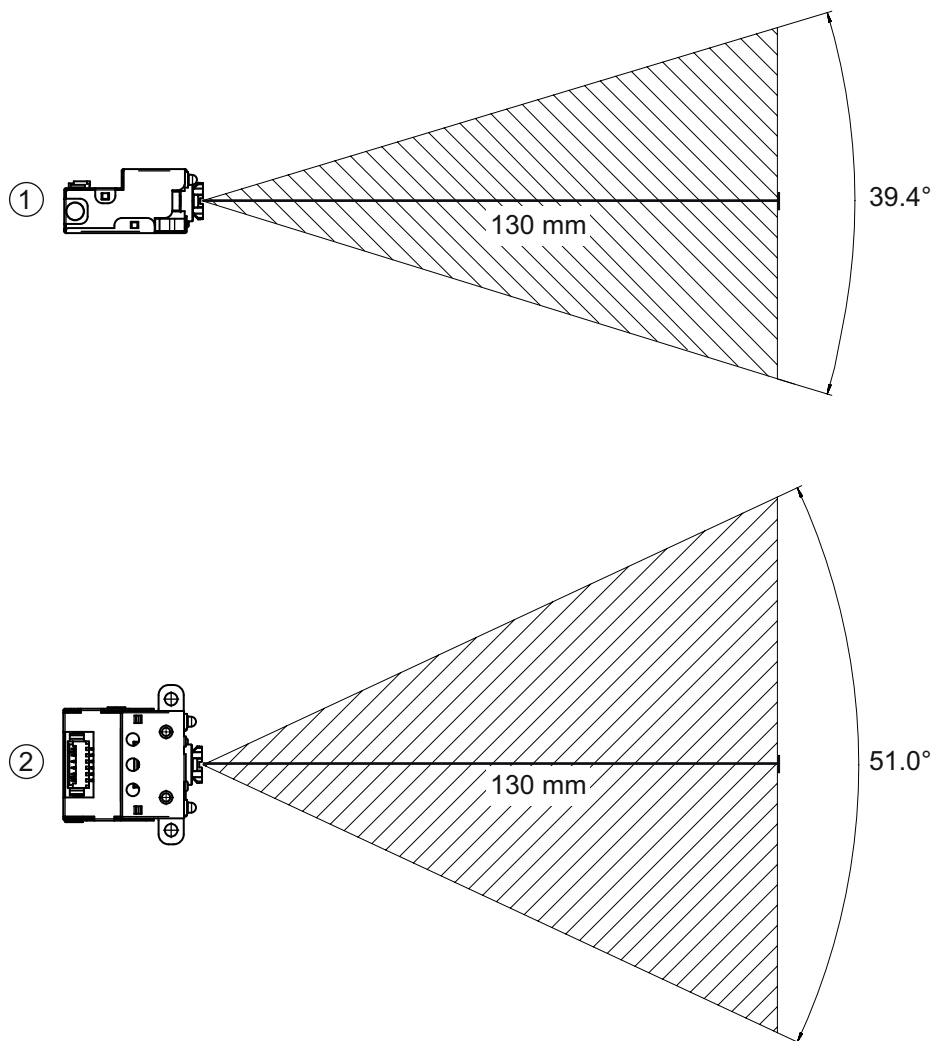

- 1 Reading field – side view
- 2 Reading field – top view

Fig. 12.1: Reading field

Tab. 12.7: Reading fields

Code type	Resolution m	Typical reading distance [mm] ([inch])
Code 39	0.190 mm (7.5 mil)	50 (2.0) 245 (9.6)
GS1 Data bar	0.267 mm (10.5 mil)	35 (1.4) 225 (8.9)
UPC	0.330 mm (13 mil)	40 (1.5) 370 (14.6)
PDF417	0.147 mm (5.8 mil)	85 (3.3) 155 (6.1)
PDF417	0.170 mm (6.7 mil)	65 (2.6) 175 (6.9)
Data Matrix	0.127 mm (5 mil)	75 (3.0) 90 (3.5)
Data Matrix	0.160 mm (6.3 mil)	70 (2.8) 135 (5.3)
Data Matrix	0.254 mm (10 mil)	50 (2.0) 205 (8.1)
Data Matrix	0.528 mm (20.8 mil)	30 (1.2) 425 (16.7)

12.3 Dimensioned drawings

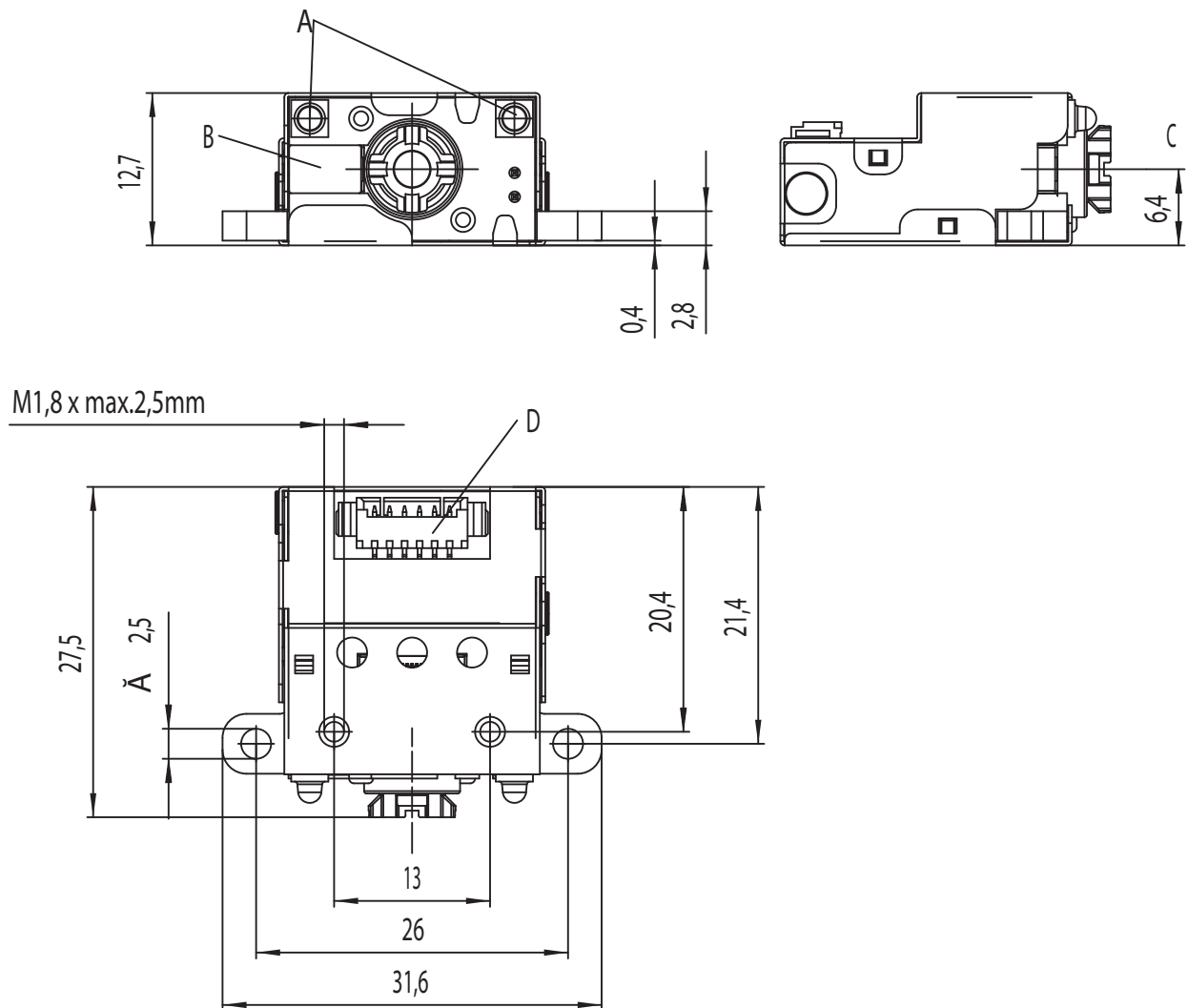

all dimensions in mm

- A 2 integrated LEDs for illumination (red light)
- B 1 integrated target LED (blue light)
- C Center of optical axis
- D Connector Molex (53261-0671), 6-pin

Fig. 12.2: DCR 50 dimensioned drawing

**NOTICE**



It is advisable to use a transparent, double-sided anti-reflective coated material when installing the scan engine behind a pane of glass. Recommended pane thickness: 1 mm; optics as flush as possible with the glass.

## 13 Order guide and accessories

### 13.1 Type overview

Tab. 13.1: Part numbers

Part no.	Part designation	Description
50135000	DCR50M2/R2	CMOS imager scan engine for 1D and 2D codes, RS 232 interface, Molex 53261-0671 connection, 6-pin

### 13.2 Accessories

Tab. 13.2: Accessories

Part no.	Part designation	Description
50128204	MA-CR	Modular adapter unit to interface device-to-host to connect to PC for evaluation
<i>Sensor Studio</i> configuration software Download at <a href="http://www.leuze.com">www.leuze.com</a> see chapter 6.2.1 "Downloading configuration software"		<i>Sensor Studio</i> designed according to the FDT/DTM concept. Contains: communication DTM and device DTM

**14 EC Declaration of Conformity**

The scan engines of the DCR 50 series have been developed and manufactured in accordance with the applicable European standards and directives.



## 15 Appendix

### 15.1 Bar code samples

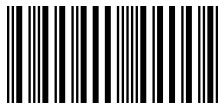

1122334455

Module 0.3

Fig. 15.1: Code type 01: Interleaved 2 of 5

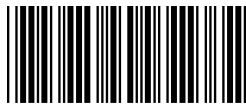

135AC

Module 0.3

Fig. 15.2: Code type 02: Code 39



a121314a

Module 0.3

Fig. 15.3: Code type 11: Codabar



abcde

Module 0.3

Fig. 15.4: Code 128



leuze

Module 0.3

Fig. 15.5: Code type 08: EAN 128



1 23456 78901 2

SC 2

Fig. 15.6: Code type 06: UPC-A



SC 3

Fig. 15.7: Code type 07: EAN 8

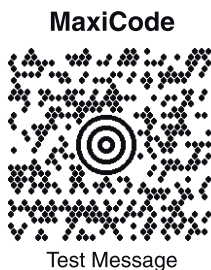

Fig. 15.8: Example codes

## 15.2 Configuration via configuration codes

The device can also be configured using configuration codes. The device parameters in the device are set and permanently saved after reading this code.





<b>General Reading Mode Settings</b>	Motion Detect Off - Default  M20200_01 A2	Motion Detect Always On  M20199_01 A3	Enable Cell phone reading enhancement  M20240_01 A4
	Disable Cell phone reading enhancement. - Default  M20241_01 B1	Set motion detect maximum brightness to 25%  M20247_01 B2	Set motion detect maximum brightness to 50%  M20246_01 B3
Set motion detect maximum brightness to 100% - Default  M20244_01 C1	<b>Data Formatting (Prefix/Suffix) Settings</b>	Disable Data Formatting - Default  M20223_01 C3	Prefix Comma  M20209_01 C4
Prefix Space  M20210_01 D1		Prefix Tab (USB Keyboard Mode Only)  M20218_02 D2	Prefix Tab (RS232 Mode Only)  M20211_01 D3
Suffix Comma  M20215_01 E1	Suffix Space  M20216_01 E2	Suffix Enter (USB Keyboard Mode Only) - Default  M20219_02 E3	Suffix Tab (USB Keyboard Mode Only)  M20220_02 E4

Fig. 15.9: DCR 50 Configuration Guide

Suffix Tab (RS232 Mode Only)  M20217 A1	Suffix Carriage Return (RS232 Mode Only)  M20212_01 A2	Suffix Carriage Return Line Feed (RS232 Mode Only) - Default  M20213_01 A3	Suffix Line Feed (RS232 Mode Only)  M20214_01 A4
Erase Suffix Data  M20208_01 B1	Convert Barcode Data to Uppercase  M20221_01 B2	Convert Barcode Data to Lowercase  M20222_01 B3	Intentionally Blank B4
Symbology Settings	Australian Post On  M20000_01 C2	Australian Post Off - Default  M20001_01 C3	Aztec On - Default  M20002_01 C4
Aztec Off  M20003_01 D1	Aztec Inverse & Normal On  M20004_01 D2	Aztec Inverse Off - Default  M20005_01 D3	BC412 On  M20006_01 D4
BC412 Off - Default  M20007_01 E1	Canada Post On  M20008_01 E2	Canada Post Off - Default  M20009_01 E3	Codabar On - Default  M20010_01 E4

Fig. 15.10: DCR 50 Configuration Guide

<p>Codabar Off</p>  <p>M20011_01</p> <p>A1</p>	<p>Codabar Checksum On</p>  <p>M20012_01</p> <p>A2</p>	<p>Codabar Checksum Off - Default</p>  <p>M20013_01</p> <p>A3</p>	<p>Remove Codabar Start and Stop Delimiters</p>  <p>M20014_01</p> <p>A4</p>
<p>Keep Codabar Start and Stop Delimiters - Default</p>  <p>M20015_01</p> <p>B1</p>	<p>Codablock A On</p>  <p>M20016_01</p> <p>B2</p>	<p>Codablock A Off - Default</p>  <p>M20017_01</p> <p>B3</p>	<p>Codablock F On</p>  <p>M20018_01</p> <p>B4</p>
<p>Codablock F Off - Default</p>  <p>M20019_01</p> <p>C1</p>	<p>Code 11 Checksum Stripped from Result On - Default</p>  <p>M20022_01</p> <p>C2</p>	<p>Code 11 Checksum Stripped from Result Off - Default</p>  <p>M20023_01</p> <p>C3</p>	<p>Code 11 On</p>  <p>M20020_01</p> <p>C4</p>
<p>Code 11 Off - Default</p>  <p>M20021_01</p> <p>D1</p>	<p>Code 11 One Digit Checksum</p>  <p>M20032_01</p> <p>D2</p>	<p>Code 11 Two Digit Checksum - Default</p>  <p>M20033_01</p> <p>D3</p>	<p>Code 128 On - Default</p>  <p>M20034_01</p> <p>D4</p>
<p>Code 128 Off</p>  <p>M20035_01</p> <p>E1</p>	<p>Code 32 (Italian Pharmacode) On</p>  <p>M20024_01</p> <p>E2</p>	<p>Code 32 (Italian Pharmacode) Off - Default</p>  <p>M20025_01</p> <p>E3</p>	<p>Code 39 On - Default</p>  <p>M20026_01</p> <p>E4</p>

Fig. 15.11: DCR 50 Configuration Guide

<p>Code 39 Off</p>  <p>M20027_01</p> <p>A1</p>	<p>Code 39 Checksum On</p>  <p>M20028_01</p> <p>A2</p>	<p>Code 39 Checksum Off - Default</p>  <p>M20029_01</p> <p>A3</p>	<p>Code 39 Checksum Stripped from Result On - Default</p>  <p>M20030_01</p> <p>A4</p>
<p>Code 39 Checksum Stripped from Result Off - Default</p>  <p>M20031_01</p> <p>B1</p>	<p>Composite On</p>  <p>M20036_01</p> <p>B2</p>	<p>Composite Off - Default</p>  <p>M20037_01</p> <p>B3</p>	<p>Data Matrix On - Default</p>  <p>M20038_01</p> <p>B4</p>
<p>Data Matrix Off</p>  <p>M20039_01</p> <p>C1</p>	<p>Data Matrix Mirror On</p>  <p>M20042_01</p> <p>C2</p>	<p>Data Matrix Mirror Off - Default</p>  <p>M20043_01</p> <p>C3</p>	<p>Data Matrix Inverse and Normal On - Default</p>  <p>M20040_01</p> <p>C4</p>
<p>Data Matrix Inverse Off</p>  <p>M20041_01</p> <p>D1</p>	<p>Data Matrix Rectangular On - Default</p>  <p>M20044_01</p> <p>D2</p>	<p>Data Matrix Rectangular Off</p>  <p>M20045_01</p> <p>D3</p>	<p>Data Matrix Rectangular Extended On</p>  <p>M20046_01</p> <p>D4</p>
<p>Data Matrix Rectangular Extended Off - Default</p>  <p>M20047_01</p> <p>E1</p>	<p>Grid Matrix On</p>  <p>M20048_01</p> <p>E2</p>	<p>Grid Matrix Off - Default</p>  <p>M20049_01</p> <p>E3</p>	<p>GS1 DataBar On - Default</p>  <p>M20050_01</p> <p>E4</p>

Fig. 15.12: DCR 50 Configuration Guide

<p>GS1 DataBar Off</p>  <p>M20051_01</p> <p>A1</p>	<p>Han Xin On</p>  <p>M20052_01</p> <p>A2</p>	<p>Han Xin Off - Default</p>  <p>M20053_01</p> <p>A3</p>	<p>Han Xin Mirror On</p>  <p>M20056_01</p> <p>A4</p>
<p>Han Xin Mirror Off - Default</p>  <p>M20057_01</p> <p>B1</p>	<p>Han Xin Inverse On</p>  <p>M20054_01</p> <p>B2</p>	<p>Han Xin Inverse Off - Default</p>  <p>M20055_01</p> <p>B3</p>	<p>Hong Kong 2 of 5 On</p>  <p>M20058_01</p> <p>B4</p>
<p>Hong Kong 2 of 5 Off - Default</p>  <p>M20059_01</p> <p>C1</p>	<p>Interleaved 2 of 5 On - Default</p>  <p>M20060_01</p> <p>C2</p>	<p>Interleaved 2 of 5 Off</p>  <p>M20061_01</p> <p>C3</p>	<p>Interleaved 2 of 5 Checksum On</p>  <p>M20062_01</p> <p>C4</p>
<p>Interleaved 2 of 5 Checksum Off - Default</p>  <p>M20063_01</p> <p>D1</p>	<p>Interleaved 2 of 5 Checksum Stripped from Result On</p>  <p>M20064_01</p> <p>D2</p>	<p>Interleaved 2 of 5 Checksum Stripped from Result Off - Default</p>  <p>M20077_01</p> <p>D3</p>	<p>Japan Post On</p>  <p>M20065_01</p> <p>D4</p>
<p>Japan Post Off - Default</p>  <p>M20066_01</p> <p>E1</p>	<p>KIX (Dutch Post) On</p>  <p>M20067_01</p> <p>E2</p>	<p>KIX (Dutch Post) Off - Default</p>  <p>M20068_01</p> <p>E3</p>	<p>Korean Post On</p>  <p>M20069_01</p> <p>E4</p>

Fig. 15.13: DCR 50 Configuration Guide

Korean Post Off - Default  M20070_01 A1	Matrix 2 of 5 On  M20071_01 A2	Matrix 2 of 5 Off - Default  M20072_01 A3	Maxicode On  M20073_01 A4
Maxicode Off - Default  M20074_01 B1	Micro PDF417 On  M20090_01 B2	Micro PDF417 Off - Default  M20091_01 B3	Micro QR Code On  M20103_01 B4
Micro QR Code Off - Default  M20104_01 C1	Mode 1 QR Code On  M20105_01 C2	Mode 1 QR Code Off - Default  M20106_01 C3	MSI Plessey Checksum On  M20079_01 C4
MSI Plessey Checksum Off - Default  M20078_01 D1	MSI Plessey Checksum Stripped from Result On  M20082_01 D2	MSI Plessey Checksum Stripped from Result Off - Default  M20083_01 D3	MSI Plessey Checksum Must Be Mod 10/11  M20081_01 D4
MSI Plessey Checksum Must Be Mod 10/10  M20080_01 E1	MSI Plessey On  M20075_01 E2	MSI Plessey Off - Default  M20076_01 E3	NEC 2 of 5 Checksum On - Default  M20086_01 E4

Fig. 15.14: DCR 50 Configuration Guide

<p>NEC 2 of 5 Checksum Off</p>  <p>M20087_01</p> <p>A1</p>	<p>NEC 2 of 5 On</p>  <p>M20084_01</p> <p>A2</p>	<p>NEC 2 of 5 Off - Default</p>  <p>M20085_01</p> <p>A3</p>	<p>PDF417 On - Default</p>  <p>M20088_01</p> <p>A4</p>
<p>PDF417 Off</p>  <p>M20089_01</p> <p>B1</p>	<p>Pharmacode On</p>  <p>M20092_01</p> <p>B2</p>	<p>Pharmacode Off - Default</p>  <p>M20093_01</p> <p>B3</p>	<p>Pharmacode Normal Barcode Decoding (Left to Right) - Default</p>  <p>M20095_01</p> <p>B4</p>
<p>Pharmacode Reverse Barcode Decoding (Right to Left)</p>  <p>M20094_01</p> <p>C1</p>	<p>QR Code On - Default</p>  <p>M20096_01</p> <p>C2</p>	<p>QR Code Off</p>  <p>M20097_01</p> <p>C3</p>	<p>QR Code Standard Only - Default</p>  <p>M20098_01</p> <p>C4</p>
<p>QR Code Mirror On</p>  <p>M20101_01</p> <p>D1</p>	<p>QR Code Mirror Off - Default</p>  <p>M20102_01</p> <p>D2</p>	<p>QR Code Inverse and Normal On</p>  <p>M20100_01</p> <p>D3</p>	<p>QR Code Inverse Only</p>  <p>M20099_01</p> <p>D4</p>
<p>Telepen On</p>  <p>M20109_01</p> <p>E1</p>	<p>Telepen Off - Default</p>  <p>M20110_01</p> <p>E2</p>	<p>Output Telepen as Numeric - Default</p>  <p>M20117_01</p> <p>E3</p>	<p>Output Telepen as ASCII</p>  <p>M20116_01</p> <p>E4</p>

Fig. 15.15: DCR 50 Configuration Guide

<p>Trioptic On</p>  <p>M20118_01</p> <p>A1</p>	<p>Trioptic Off - Default</p>  <p>M20119_01</p> <p>A2</p>	<p>Reverse Trioptic On</p>  <p>M20120_01</p> <p>A3</p>	<p>Reverse Trioptic Off - Default</p>  <p>M20121_01</p> <p>A4</p>
<p>Keep Trioptic Start and Stop Delimiters</p>  <p>M20122_01</p> <p>B1</p>	<p>Remove Trioptic Start and Stop Delimiters - Default</p>  <p>M20123_01</p> <p>B2</p>	<p>Straight 2 of 5 On</p>  <p>M20107_01</p> <p>B3</p>	<p>Straight 2 of 5 Off - Default</p>  <p>M20108_01</p> <p>B4</p>
<p>UK Royal Mail On</p>  <p>M20124_01</p> <p>C1</p>	<p>UK Royal Mail Off - Default</p>  <p>M20125_01</p> <p>C2</p>	<p>UPC/EAN On - Default</p>  <p>M20126_01</p> <p>C3</p>	<p>UPC/EAN Off</p>  <p>M20127_01</p> <p>C4</p>
<p>UPC Supplemental On</p>  <p>M20128_01</p> <p>D1</p>	<p>UPC Supplemental Off - Default</p>  <p>M20129_01</p> <p>D2</p>	<p>UPC E Expansion On</p>  <p>M20132_01</p> <p>D3</p>	<p>UPC E Expansion Off - Default</p>  <p>M20133_01</p> <p>D4</p>
<p>Convert UPC-A to EAN-13</p>  <p>M20134_01</p> <p>E1</p>	<p>Do Not Convert UPC-A to EAN-13 - Default</p>  <p>M20135_01</p> <p>E2</p>	<p>Transmit UPC-A Check Digit</p>  <p>M20140_01</p> <p>E3</p>	<p>Do Not Transmit UPC-A Check Digit - Default</p>  <p>M20141_01</p> <p>E4</p>

Fig. 15.16: DCR 50 Configuration Guide

Transmit UPC-A Number System  M20142_01 A1	Do Not Transmit UPC-A Number System - Default  M20143_01 A2	Do Not Transmit UPC-E Check Digit - Default  M20145_01 A3	Transmit UPC-E Number System  M20146_01 A4
Do Not Transmit UPC-E Number System - Default  M20147_01 B1	Convert EAN-8 to EAN-13  M20130_01 B2	Do Not Convert EAN-8 to EAN-13 - Default  M20131_01 B3	Transmit UPC-E Check Digit  M20144_01 B4
Convert Bookland EAN-13 to ISBN  M20136_01 C1	Do Not Convert Bookland EAN-13 to ISBN - Default  M20137_01 C2	Convert Bookland EAN-13 to ISSN  M20138_01 C3	Do Not Convert Bookland EAN-13 to ISSN - Default  M20139_01 C4
Transmit EAN-8 Check Digit  M20148_01 D1	Do Not Transmit EAN-8 Check Digit - Default  M20149_01 D2	Transmit EAN-13 Check Digit  M20150_01 D3	Do Not Transmit EAN-13 Check Digit - Default  M20151_01 D4
UPU ID Tags On  M20152_01 E1	UPU ID Tags Off - Default  M20153_01 E2	USPS Intelligent Mail On  M20154_01 E3	USPS Intelligent Mail Off - Default  M20155_01 E4

Fig. 15.17: DCR 50 Configuration Guide











USPS Planet On  M20156_01 A1	USPS Planet Off - Default  M20157_01 A2	USPS Postnet On  M20158_01 A3	USPS Postnet Off - Default  M20159_01 A4
Keyboard Language Settings	List Installed Languages  M20180_01 B2	Get Active Language  M20179_01 B3	Keyboard Support: US English Keyboard Mapping for Windows - Default  M20182_01 B4
	Keyboard Support: English Keyboard Mapping for Apple  M20184_01 C1	Keyboard Support: French- Belgian Keyboard Mapping for Windows  M20181_01 C2	Keyboard Support: French Keyboard Mapping for Windows  M20185_01 C3
Keyboard Support: German Keyboard Mapping for Apple  M20187_01 D1	Keyboard Support: German Keyboard Mapping for Windows  M20188_01 D2	Keyboard Support: German-Swiss Keyboard Mapping for Apple  M20189_01 D3	Keyboard Support: German-Swiss Keyboard Mapping for Windows  M20190_01 D4
Keyboard Support: Italian Keyboard Mapping for Apple  M20191_01 E1	Keyboard Support: Japanese Keyboard Mapping for Windows  M20192_01 E2	Keyboard Support: Russian Keyboard Mapping for Windows  M20194_01 E3	Keyboard Support: Spanish-Latin American Keyboard Mapping for Windows  M20193_01 E4

Fig. 15.18: DCR 50 Configuration Guide

Keyboard Support: Spanish Keyboard Mapping for Windows   M20195_01  A1	Keyboard Support: Spanish Keyboard Mapping for Apple   M20196_01  A2	Keyboard Support: UK English Keyboard Mapping for Windows   M20197_01  A3	Keyboard Support: US International (Universal) Keyboard Mapping for Windows   M20198_01  A4
Data Encoding: Raw ASCII to Keyboard XML File Lookup - Default   M20203_01  B1	Data Encoding: UTF8 to Unicode Codepoint - Alt Sequences for Windows   M20204_01  B2	USB Settings	USB Downloader Mode   M20177_01  B4
USB Keyboard Mode - Default   M20178_01  C1	Enable HID POS Mode   M20225_01  C2	Enable CDC VCOM Mode   M20226_01  C3	Enable USB VCOM mode   M20250_01  C4
RS232 Settings	Reset to RS232 Factory Defaults   M20112_01  D2	RS232 Interface - 1200 Baud Rate   M20160_01  D3	RS232 Interface - 2400 Baud Rate   M20161_01  D4
RS232 Interface - 4800 Baud Rate   M20162_01  E1	RS232 Interface - 9600 Baud Rate   M20163_01  E2	RS232 Interface - 19200 Baud Rate   M20164_01  E3	RS232 Interface - 38400 Baud Rate   M20165_01  E4

Fig. 15.19: DCR 50 Configuration Guide

RS232 Interface - 57600 Baud Rate  M20166_01 A1	RS232 Interface - 115200 Baud Rate - Default  M20167_01 A2	RS232 Interface - 7 Data Bits  M20168_01 A3	RS232 Interface - 8 Data Bits - Default  M20169_01 A4
RS232 Interface - 1 Stop Bit - Default  M20170_01 B1	RS232 Interface - 2 Stop Bits  M20171_01 B2	RS232 Interface - Even Parity  M20172_01 B3	RS232 Interface - No Parity  M20173_01 B4
RS232 Interface - Odd Parity  M20174_01 C1	RS232 Interface Flow Control On  M20175_01 C2	RS232 Interface Flow Control Off - Default  M20176_01 C3	Enable Packet Mode  M20238_01 C4
Enable Raw Mode - Default  M20239_01 D1	Enable RS-232 Serial mode - Default  M20251_01 D2	Scan Delay Settings	
Disable Duplicate Scan Delay - Default  M20229_01 D4	Set Duplicate Scan delay to 1 Second  M20230_01 E1	Set Duplicate Scan delay to 2 Seconds  M20231_01 E2	Set Duplicate Scan delay to 3 Seconds  M20232_01 E3
Set Duplicate Scan delay to 5 Seconds  M20233_01 E4			

Fig. 15.20: DCR 50 Configuration Guide







Set Duplicate Scan delay to 10 Seconds  M20234_01 A1	Set Duplicate Scan delay to 30 Seconds  M20235_01 A2	Set Duplicate Scan delay to 1 hour  M20236_01 A3	Set Duplicate Scan delay to 1 day  M20237_01 A4
Reader/Modem Command Settings	Output Reader Configuration  M20113_01 B2	Get Reader Parameters  M20114_01 B3	Intentionally Blank B4
	Reset, Clear and Save Reader Settings  M20111_01 C2	Intentionally Blank C3	Intentionally Blank C4
Intentionally Blank D1	Intentionally Blank D2	Intentionally Blank D3	Intentionally Blank D4
Intentionally Blank E1	Intentionally Blank E2	Intentionally Blank E3	Intentionally Blank E4

Fig. 15.21: DCR 50 Configuration Guide